

FEATURES

- | High surge current handling capability
- | High energy absorption capability
- | Wide operating voltages ranging from 10Vrms to 510Vrms
- | Fast response time of less than 25ns, instantly clamping the transient over voltage
- | Low clamping voltages, providing better surge protection
- | Low capacitance values, providing digital switching circuitry protection
- | High insulation resistance, preventing electric arcing to the adjacent devices or circuits



07D

APPLICATIONS

- | Surge protection of consumer equipment
- | Surge protection of communication, measuring and controller instrument
- | Surge protection in electronic home appliances, gas and petroleum appliances
- | Relay and electromagnetic valve surge absorption
- | Transistor, Diode, IC, Thyristor or Triac semiconductor protection

APPROVALS

RoHS	Compliance with 2011/65/EU
HF	Compliance with IEC61249-2-21:2003

GENERAL CHARACTERISTICS DEFINITION

- | Operating Temperature Range : -40°C ~ +85°C
- | Storage Temperature Range : -40°C ~ +125°C
- | Working Surface Temperature : +115°C
- | Insulation Resistance : >100MΩ

MATERIAL

- | Coating: Epoxy Resin
- | Lead Wire: The Copper Wire
- | Electrode: Silver Solder
- | Disk: Zinc Oxide

ELECTRICAL CHARACTERISTICS

Symbol		Mximum Allowable Voltage		Varistor Voltage @1mA	Mximum Clamping Voltage		Withstanding Surge Current (8/20µs)		Maximum Energy (10/1000µs)		Rated Power	Typical Capacitance (Reference)
Standard	High Surge	V _{AC} (V)	V _{DC} (V)	(V)	V _C (V)	I _p (A)	I(A) Standard	I(A) High Surge	(J) Standard	(J) High Surge	(W)	@1KHz (pF)
07D180L	07D180LJ	10	14	18(15-21)	38	2.5	250	500	2.1	2.4	0.02	1400
07D220K	07D220KJ	14	18	22(20-24)	43	2.5	250	500	2.4	2.8	0.02	1150
07D270K	07D270KJ	17	22	27(24-30)	53	2.5	250	500	2.8	3.0	0.02	930
07D330K	07D330KJ	20	26	33(30-36)	65	2.5	250	500	3.5	4.0	0.02	760
07D390K	07D390KJ	25	31	39(35-43)	77	2.5	250	500	4.2	4.6	0.02	640
07D470K	07D470KJ	30	38	47(42-52)	93	2.5	250	500	5.0	5.2	0.02	530
07D560K	07D560KJ	35	45	56(50-62)	110	2.5	250	500	6.2	6.5	0.02	450
07D680K	07D680KJ	40	56	68(61-75)	135	2.5	250	500	7.2	7.5	0.02	370
07D820K	07D820KJ	50	65	82(74-90)	135	10	1200	1750	9.8	10.0	0.25	600
07D101K	07D101KJ	60	85	100(90-110)	165	10	1200	1750	11.6	12.0	0.25	500
07D121K	07D121KJ	75	100	120(108-132)	200	10	1200	1750	14.0	14.2	0.25	420
07D151K	07D151KJ	95	125	150(135-165)	250	10	1200	1750	16.8	17.0	0.25	330
07D181K	07D181KJ	115	150	180(162-198)	300	10	1200	1750	18.2	22.0	0.25	280
07D201K	07D201KJ	130	170	200(185-225)	330	10	1200	1750	25.2	27.0	0.25	250
07D221K	07D221KJ	140	180	220(198-242)	360	10	1200	1750	26.5	29.0	0.25	230
07D241K	07D241KJ	150	200	240(216-262)	395	10	1200	1750	28.0	30.0	0.25	210
07D271K	07D271KJ	175	225	270(243-297)	455	10	1200	1750	32.2	33.0	0.25	185
07D301K	07D301KJ	190	250	300(270-330)	505	10	1200	1750	35.0	36.0	0.25	165
07D331K	07D331KJ	210	275	330(297-363)	550	10	1200	1750	37.8	38.0	0.25	150
07D361K	07D361KJ	230	300	360(324-396)	595	10	1200	1750	42.0	43.0	0.25	140
07D391K	07D391KJ	250	320	390(351-429)	650	10	1200	1750	46.2	47.0	0.25	130
07D431K	07D431KJ	275	350	430(387-473)	710	10	1200	1750	50.4	51.0	0.25	115
07D471K	07D471KJ	300	385	470(423-517)	775	10	1200	1750	56.0	57.0	0.25	105
07D511K	07D511KJ	320	415	510(459-561)	845	10	1200	1750	57.0	58.0	0.25	100
07D561K	07D561KJ	350	460	560(504-616)	920	10	1200	1750	58.0	61.0	0.25	90
07D621K	07D621KJ	385	505	620(558-682)	1025	10	1200	1750	61.6	68.0	0.25	80
07D681K	07D681KJ	420	560	680(612-748)	1120	10	1200	1750	62.5	75.0	0.25	75
07D751K	07D751KJ	460	615	750(675-825)	1240	10	1200	1750	67.2	80.0	0.25	65
07D821K	07D821KJ	510	670	820(738-902)	1355	10	1200	1750	72.0	87.0	0.25	65

CHARACTERISTIC CURVES

Items	Test condition/Description					
Varistor Voltage	The voltage across the varistor measured at 1 mA DC, can be called Vb					
Maximum Allowable Voltage	Maximum continuous sine wave(RMS) or DC voltage which may be applied					
Maximum Clamping Voltage	Peak voltage across the varistor with a specified peak impulse current of 8/20μs waveform					
Rated Power	The maximum average power that can be applied within the specified ambient temperature					
Withstanding Surge Current	The maximum current within the varistor voltage change of less than ±10% when one impulse current(8/20μs) applied					
Energy	The max.energy absorbed with a varistor voltage change of less than ± 10% when one impulse (10/1000μs) is applied					
Varistor Voltage Temperature Coefficient	$\left \frac{V_{b@85^{\circ}\text{C}} - V_{b@25^{\circ}\text{C}}}{V_{b@25^{\circ}\text{C}}} \times \frac{1}{60} \times 100\% \left(\%/^{\circ}\text{C} \right) \right \leq 0.05\% / ^{\circ}\text{C}$ $\left \frac{V_{b@-40^{\circ}\text{C}} - V_{b@25^{\circ}\text{C}}}{V_{b@25^{\circ}\text{C}}} \times \frac{1}{65} \times 100\% \left(\%/^{\circ}\text{C} \right) \right \leq 0.05\% / ^{\circ}\text{C}$					
Surge Life	The max.current with a varistor voltage change of less than ±10% when 10,000 times impulse current (8/20μs) are applied at intervals of 20 seconds at room temperature <table border="1" style="margin-left: auto; margin-right: auto;"> <tr> <td rowspan="2">07D Series</td> <td>180L to 680K</td> <td>25A(8/20μs)</td> </tr> <tr> <td>820K to 821K</td> <td>50A(8/20μs)</td> </tr> </table>	07D Series	180L to 680K	25A(8/20μs)	820K to 821K	50A(8/20μs)
07D Series	180L to 680K		25A(8/20μs)			
	820K to 821K	50A(8/20μs)				

CHARACTERISTIC CURVES

Items	Test condition/Description	Specifications															
High Temperature Storage	Ambient Temp:125±2°C Duration:1000 hrs	$ \Delta V_{1_{mA}} / V_{1_{mA}} \leq 5\%$															
Low Temperature Storage	Ambient Temp:-40±2°C Duration:1000 hrs	$ \Delta V_{1_{mA}} / V_{1_{mA}} \leq 5\%$															
Humidity	Ambient Temp:40±2°C,90~95% R.H. Duration:1000 hrs	$ \Delta V_{1_{mA}} / V_{1_{mA}} \leq 5\%$															
Temperature Cycle	The conditions shown below shall be repeated 5 cycles <table border="1" style="margin-left: auto; margin-right: auto;"> <thead> <tr> <th>Step</th> <th>Temperature(°C)</th> <th>Period(minutes)</th> </tr> </thead> <tbody> <tr> <td>1</td> <td>-40±3</td> <td>30±3</td> </tr> <tr> <td>2</td> <td>Room temperature</td> <td>15±3</td> </tr> <tr> <td>3</td> <td>125±3</td> <td>30±3</td> </tr> <tr> <td>4</td> <td>Room temperature</td> <td>15±3</td> </tr> </tbody> </table>	Step	Temperature(°C)	Period(minutes)	1	-40±3	30±3	2	Room temperature	15±3	3	125±3	30±3	4	Room temperature	15±3	No visible damage $ \Delta V_{1_{mA}} / V_{1_{mA}} \leq 5\%$
Step	Temperature(°C)	Period(minutes)															
1	-40±3	30±3															
2	Room temperature	15±3															
3	125±3	30±3															
4	Room temperature	15±3															
High Temperature Load	Ambient Temp:85±2°C ,Duration:1000 hrs Load:Max.Allowable Voltage in AC eara	$ \Delta V_{1_{mA}} / V_{1_{mA}} \leq 10\%$															
Damp Heat Load	Ambient Temp:40±2°C ,90~95% R.H. Duration:1000 hrs Load:Max.Allowable Voltage	No visible damage $ \Delta V_{1_{mA}} / V_{1_{mA}} \leq 10\%$															
Voltage Proof	Metal balls method,2500Vac 1 min	No visible damage															

WAVE SOLDERING

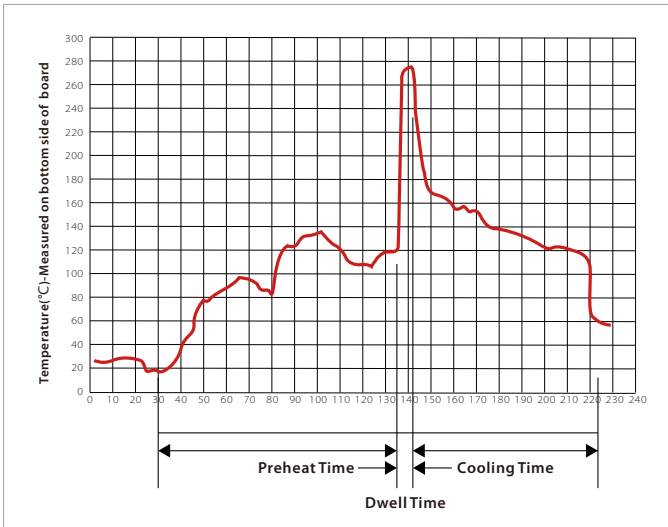

Wave Parameter		Lead-free assembly
Pre Heat	Temperature Min	100°C
	Temperature Max	150°C
	Time(min to max)	60 – 180 secs
Solder pot Temperature		280°C Max
Solder Dwell Time		2-5 seconds

PACKAGE INFORMATION

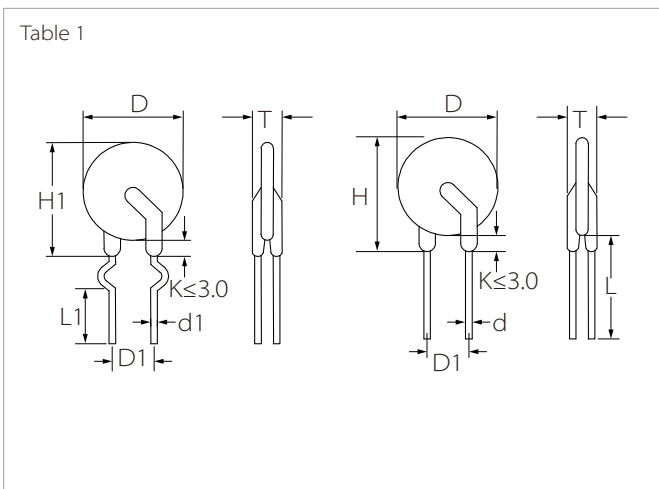

Symbol	Dimension(mm)
H(max)	14.0
H1(max)	13.5
L(min)	20.0
L1(min)	15.0
D(max)	9.0
D1(±0.8)	5.0
T(max)	Table2
d(±0.05)	0.6
d1(±0.4)	1.2

Table 2		Tmax(mm)					
07D180L	3.8	07D820K	4.1	07D271K	4.5	07D561K	6.2
07D220K	3.8	07D101K	4.3	07D301K	4.7	07D621K	6.4
07D270K	3.9	07D121K	4.5	07D331K	4.8	07D681K	6.4
07D330K	3.9	07D151K	4.8	07D361K	5.0	07D751K	6.5
07D390K	4.1	07D181K	4.1	07D391K	5.1	07D821K	6.9
07D470K	4.1	07D201K	4.1	07D431K	5.3		
07D560K	4.5	07D221K	4.2	07D471K	5.6		
07D680K	4.5	07D241K	4.3	07D511K	5.8		

ORDERING INFORMATION

Part Number	Component Package	Package
07D SERIES	07D	1000PCS

Headquarters

No.3387 Shendu Road Pujiang
I&E Park
Minhang Shanghai China
201000

Hotline

400-021-5756

Web

<https://www.semiware.com>

Sales Center

Tel: 86-21-3463-7458
Email: sales18@semiware.com

Customer Service

Tel: 86-21-5484-1001
Email: sales17@semiware.com

Technical Support

Tel: 86-21-3463-7654
Email: fae01@semiware.com

Complaint & Suggestions

Tel: 86-21-3463-7172
Ext: 8868
Email: cs03@semiware.com

By QR Code

Website



Wechat

To find your local partner within Semiware's global network: www.semiware.com

© 2022 Semiware Semiconductor Inc.

The content of this document has been carefully checked and understood. However, neither Semiware nor its subsidiaries assume any liability whatsoever for any errors or inaccuracies of this document and the consequences thereof. Published specifications are subject to change without notice. Product suitability for any area of application must ultimately be determined by the customer. In all cases, products must never be operated outside their published specifications. Semiware does not guarantee the availability of all published products. This disclaimer shall be governed by substantive Chinese law and resulting disputes shall be settled by the courts at the place of business of Semiware. Latest publications and a complete disclaimer can be downloaded from the Semiware website. All trademarks recognized.