

FEATURES

- | Quad programmable transient suppressor.
- | Wide negative firing voltage range: $V_{GKRM} = -167V$ max.
- | Low dynamic switching voltage: V_{FRM} and $V_{GK(BD)}$
- | Low gate triggering current: $I_{GT} = 5mA$ max.
- | Peak pulse current: $I_{PP} = 30A$ for 10/1000 μs surge.
- | Holding current: $I_H = 150mA$ min.

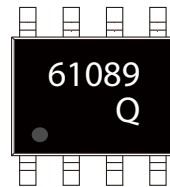

SOP-8



Marking

APPLICATIONS

- | Switch Line Card
- | Access Network Line Card
- | PBX
- | VoIP

APPROVALS

RoHS	Compliance with 2011/65/EU
HF	Compliance with IEC61249-2-21:2003

ELECTERICAL CAHRACTERISTIC

Symbol	Parameters
I_{DRM}	Off-state current
I_H	Holding current
V_{BO}	Break-over voltage
V_F	Forward voltage
V_{FRM}	Peak forward recovery voltage
$V_{GK(BD)}$	Gate-cathode impulse break-over voltage
I_{GKS}	Gate reverse current
I_{GT}	Gate trigger current
V_{GT}	Gate-cathode trigger voltage
C_{KA}	Cathode-anode off-state capacitance

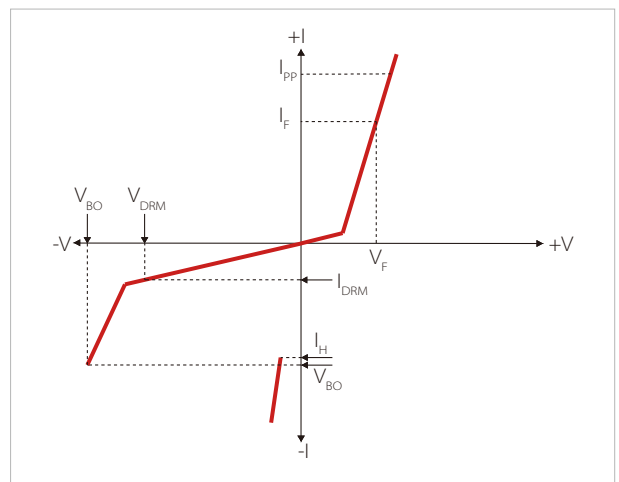

ABSOLUTE MAXIMUM RATINGS (T_A = 25°C)

Symbol	Parameter	Value	Unit	
T _{STG}	Storage temperature range	-40 to +150	°C	
T _J	Junction temperature			
Non-repetitive peak on-state pulse current				
I _{TSP}	(Telcordia (Bellcore) GR-1089-CORE, Issue 2, February)	10/1000μs	30	A
	(ITU-T K.20/21 & K.45/44 open-circuit voltage 10/700μs)	5/310μs	40	
	(Telcordia (Bellcore) GR-1089-CORE, Issue 2, February)	1.2/50μs	100	
V _{PP}	Non-repetitive peak pulse voltage(10/700μs)	2000	V	
I _{TSM}	Non repetitive surge peak on-state current (sinusoidal) 60Hz (Note 2)900s	0.5	A	
V _{DRM}	Maximum voltage Line/Ground	-170	V	
V _{GKRM}	Maximum voltage Gate/Line	-167		

Note1: 5/310μs means current wave, and its rise time is 5μs, fall time is 310μs.
 10/700μs means voltage wave, and its rise time is 10μs, fall time is 700μs.

Note2: Initially the protector must be in thermal equilibrium with T_J = 25 °C. EIA/JESD51-2 environment and EIA/JESD51-7 high effective thermal conductivity test board (multi-layer) connected with 0.6 mm printed wiring track widths

TESTING STANDARDS

Type	Wave Sharp		V _{PP} /I _{PP}
ITU-T K.20/21 and K.45	Voltage	10/700μs	2000V
	Current	5/310μs	40A

ELECTRICAL CHARACTERISTICS (T_A = 25°C)

Symbol	Parameter	Test conditions	Value			Unit
			Min.	Typ.	Max.	
Parameters related to the diode						
V _F	Forward voltage	I _F =5A, t _w =200μs	-	-	3	V
V _{FRM}	Peak forward recovery voltage	10/700μs, I _F =40A, R _S =55Ω, V _{GG} =-48V, C _G =100nF	-	12	-	
Parameters related to the protection thyristor						
I _{DRM}	Off-state current	V _{DRM} =-170V, V _{GK} =0V	-	-	-5	μA
V _{BO}	Break-over voltage	10/700μs, I _F =-40A, R _S =55Ω, V _{GG} =-48V, C _G =100nF	-	-	64	V
I _H	Holding current	I _T =-1A, di/dt=1A/ms, V _{GG} =-100V	-150	-	-	mA
I _{GKS}	Gate reverse current	V _{GG} =V _{GK} =-167V, V _{KA} =0, T _J =25°C	-	-	-5	μA
I _{GT}	Gate trigger current	I _T =3A, t _{p(g)} ≥20μs, V _{GG} =-100V	-	-	5	mA
V _{GT}	Gate trigger voltage		-	-	2.5	V
C _{AK}	Anode-cathode off-state capacitance	f=1MHz, V _D =1V, I _G =0A, V _D =-3V	-	-	70	pF

REFLOW PROFILE

Reflow Condition		Lead-free assembly
Pre Heat	Temperature Min	150°C
	Temperature Max	200°C
	Time(min to max)	60~180 secs
Average ramp up rate (Liquidus)Temp (T _L) to peak T _s (max) to T _L - Ramp-up Rate		3°C/second max
Reflow	Temperature (T _L) (Liquidus)	217°C
	Time(min to max)(t _s)	60~150 seconds
Peak Temperature (T _p)		260 °C
Time within 5°C of actual peak Temperature (t _p)		20~40 seconds
Ramp-down Rate		6°C/second max
Time 25°C to peak Temperature (T _p)		8 minutes max.
Do not exceed		260°C

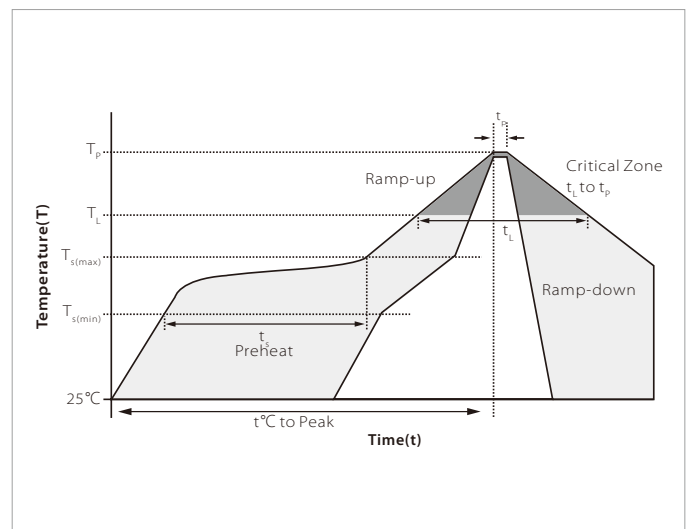

SOP PACKAGE TOP VIEW AND DEVICE SYMBOL

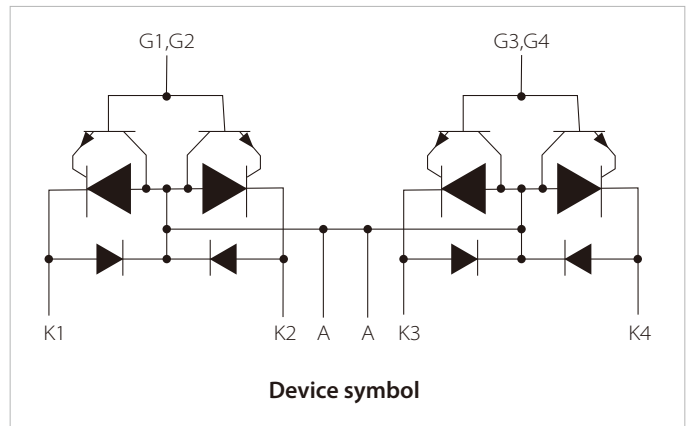
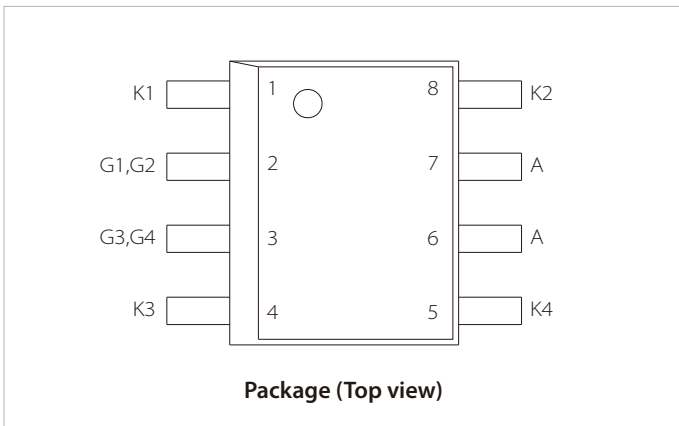

PACKAGE MECHANICAL DATA

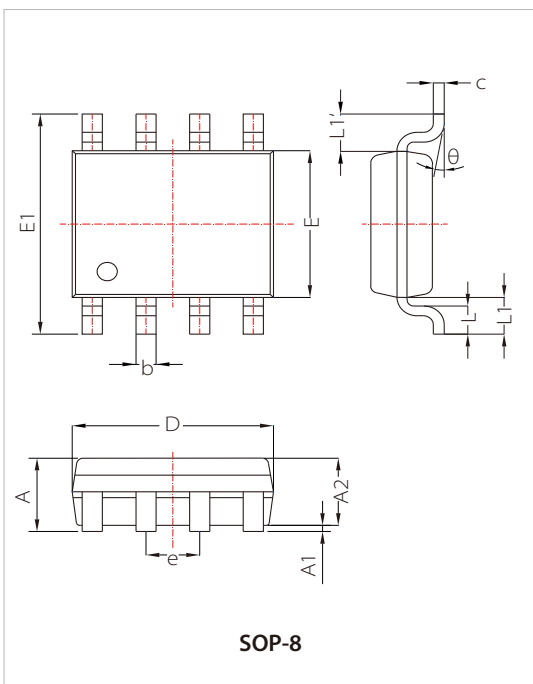

Ref.	Dimensions					
	Millimeters			Inches		
	Min.	Typ.	Max.	Min.	Typ.	Max.
A	1.40		1.70	0.055		0.067
A1	0.05		0.15	0.002		0.006
A2	1.35		1.55	0.053		0.061
b	0.31		0.51	0.012		0.020
c	0.17		0.25	0.007		0.010
D	4.70		5.10	0.185		0.201
E	3.80		4.00	0.150		0.157
E1	5.80		6.20	0.228		0.244
e	1.14	1.27	1.40	0.045	0.050	0.055
L	0.62		0.77	0.024		0.030
L1	1.00	1.02	1.04	0.039	0.040	0.041
L1-L1'			0.12			0.005
θ	0°		8°	0°		8°

ORDERING INFORMATION

Part Number	Component Package	QTY/Reel	Reel
STP61089Q	SOP-8	4000PCS	13"

Headquarters

No.3387 Shendu Road Pujiang
I&E Park
Minhang Shanghai China
201000

Hotline

400-021-5756

Web

<https://www.semiware.com>

Sales Center

Tel: 86-21-3463-7458
Email: sales18@semiware.com

Customer Service

Tel: 86-21-5484-1001
Email: sales17@semiware.com

Technical Support

Tel: 86-21-3463-7654
Email: fae01@semiware.com

Complaint & Suggestions

Tel: 86-21-3463-7172
Ext: 8868
Email: cs03@semiware.com

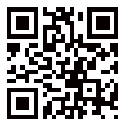
By QR Code

Website



Wechat

To find your local partner within Semiware's global network: www.semiware.com

© 2022 Semiware Semiconductor Inc.

The content of this document has been carefully checked and understood. However, neither Semiware nor its subsidiaries assume any liability whatsoever for any errors or inaccuracies of this document and the consequences thereof. Published specifications are subject to change without notice. Product suitability for any area of application must ultimately be determined by the customer. In all cases, products must never be operated outside their published specifications. Semiware does not guarantee the availability of all published products. This disclaimer shall be governed by substantive Chinese law and resulting disputes shall be settled by the courts at the place of business of Semiware. Latest publications and a complete disclaimer can be downloaded from the Semiware website. All trademarks recognized.