

## FEATURES

- | I(hold): 0.05~3.5A
- | Very high voltage surge capabilities
- | Available in lead-free version
- | Fast response to fault current
- | RoHS compliant, Lead- Free and Halogen-Free
- | Low resistance
- | Compact design saves board space
- | Compatible with high temperature solders



## APPLICATIONS

- |  |   |
|--|---|
| <ul style="list-style-type: none"> <li>  USB peripherals</li> <li>  Disk drives</li> <li>  CD-ROMs</li> <li>  General electronics</li> <li>  Set-top-box and HDMI</li> </ul> | <ul style="list-style-type: none"> <li>  Mobile Internet Device (MID)</li> <li>  PDAs / digital cameras</li> <li>  Game console port protection</li> <li>  Plug and play protection for peripherals</li> <li>  Mobile phones - battery and port protection</li> </ul> |
|--|---|

## ENVIRONMENTAL SPECIFICATIONS

Test	Conditions	Resistance change
Passive aging	+85°C, 1000 hrs	±5% typica
Humidity aging	+85°C, 85%R.H., 168 hours	±5% typical
Thermal shock	+85°C to -40°C, 20times	±33% typical
Resistance to solvent	MIL-STD-202, Method 215	No change
Vibration	MIL-STD-202, Method 201	No change
Ambient operating conditions : - 40°C to +85°C		
Maximum surface temperature of the device in the tripped state is 125 °C		

## PERFORMANCE SPECIFICATION

Type Number	$I_{hold}$	$I_{trip}$	$V_{max}$	Max. Time to Trip		$I_{max}$	$P_{dtyp}$	$Ri_{min}$	$R1_{max}$
	A	A	$V_{DC}$	Current (A)	$T_{max}$ (S)	A	W	$\Omega$	$\Omega$
SMD1206-005	0.05	0.15	60	0.25	1.50	10	0.4	3.60	50
SMD1206-010	0.10	0.25	60	0.50	1.00	10	0.4	1.60	15
SMD1206-010/33	0.10	0.25	33	0.50	1.00	10	0.4	1.60	15
SMD1206-012	0.12	0.29	60	0.50	1.00	10	0.4	1.60	15
SMD1206-012/48	0.12	0.29	48	0.50	1.00	10	0.4	1.60	15
SMD1206-016	0.16	0.37	16	1.00	0.30	10	0.4	1.00	6
SMD1206-016/24	0.16	0.37	24	1.00	0.30	10	0.4	1.00	6
SMD1206-016/33	0.16	0.37	33	1.00	0.30	10	0.4	1.00	6
SMD1206-020	0.20	0.46	24	8.00	0.08	10	0.6	0.35	2.7
SMD1206-020/30	0.20	0.46	30	8.00	0.08	10	0.6	0.35	2.7
SMD1206-025	0.25	0.50	16	8.00	0.08	10	0.6	0.35	2.5
SMD1206-025/24	0.25	0.50	24	8.00	0.08	10	0.6	0.35	2.5
SMD1206-025/30	0.25	0.50	30	8.00	0.08	10	0.6	0.35	2.5
SMD1206-035	0.35	0.75	6	8.00	0.10	35	0.6	0.25	1.3
SMD1206-035/16	0.35	0.75	16	8.00	0.10	35	0.6	0.25	1.3
SMD1206-035/30	0.35	0.75	30	8.00	0.10	35	0.6	0.25	1.3
SMD1206-050	0.50	1.00	6	8.00	0.10	35	0.6	0.15	0.7
SMD1206-050/13.2	0.50	1.00	13.2	8.00	0.10	35	0.6	0.15	0.7
SMD1206-050/16	0.50	1.00	16	8.00	0.10	35	0.6	0.15	0.7
SMD1206-050/24	0.50	1.00	24	8.00	0.10	35	0.6	0.15	0.7
SMD1206-050/30	0.50	1.00	30	8.00	0.10	35	0.6	0.15	0.7
SMD1206-075	0.75	1.50	6	8.00	0.20	35	0.6	0.09	0.5
SMD1206-075/13.2	0.75	1.50	13.2	8.00	0.20	35	0.6	0.09	0.5
SMD1206-075/16	0.75	1.50	16	8.00	0.20	35	0.6	0.09	0.5
SMD1206-075/24	0.75	1.50	24	8.00	0.20	35	0.6	0.09	0.5
SMD1206-075/30	0.75	1.50	30	8.00	0.20	35	0.6	0.09	0.5
SMD1206-100	1.00	1.80	6	8.00	0.30	35	0.6	0.05	0.27
SMD1206-100/16	1.00	1.80	16	8.00	0.30	35	0.6	0.05	0.27
SMD1206-100/24	1.00	1.80	24	8.00	0.30	35	0.6	0.05	0.27
SMD1206-110	1.10	2.20	6	8.00	0.30	35	0.6	0.04	0.25
SMD1206-110/16	1.10	2.20	16	8.00	0.30	35	0.6	0.04	0.25
SMD1206-110/24	1.10	2.20	24	8.00	0.30	35	0.6	0.04	0.25
SMD1206-150	1.50	3.00	6	8.00	0.30	35	0.8	0.025	0.13
SMD1206-150/13.2	1.50	3.00	13.2	8.00	0.30	35	0.8	0.025	0.13
SMD1206-150/16	1.50	3.00	16	8.00	0.30	35	0.8	0.025	0.13
SMD1206-200	2.00	3.50	6	8.00	1.50	35	0.8	0.015	0.08
SMD1206-200/12	2.00	3.50	12	8.00	1.50	35	0.8	0.015	0.08
SMD1206-250	2.50	5.00	6	8.00	2.00	35	0.8	0.01	0.06
SMD1206-260	2.60	5.20	6	8.00	2.00	35	0.8	0.01	0.06
SMD1206-260/12	2.60	5.20	12	8.00	2.00	35	0.8	0.01	0.06
SMD1206-300	3.00	6	6	8.00	4.00	35	1.0	0.01	0.05
SMD1206-350	3.50	7	6	10.00	5.00	35	1.2	0.005	0.04

$V_{max}$  = Maximum operating voltage device can withstand without damage at rated current ( $I_{max}$ ).

$I_{max}$  = Maximum fault current device can withstand without damage at rated voltage ( $V_{max}$ ).

$I_{hold}$  = Hold Current. Maximum current device will not trip in 25°C still air.

$I_{trip}$  = Trip Current. Minimum current at which the device will always trip in 25°C still air.

$P_{dtyp}$  = Power dissipation when device is in the tripped state in 25°C still air environment at rated voltage.

$Ri_{min/max}$  = Minimum/Maximum device resistance prior to tripping at 25°C.

$R1_{max}$  = Maximum device resistance is measured one hour post reflow.

## THERMAL DERATING CHART-IH(A)

Part Number	Ambient Operation Temperature								
	-40 °C	-20 °C	0 °C	25 °C	40 °C	50 °C	60 °C	70 °C	85 °C
SMD1206-005	0.074	0.066	0.058	0.05	0.0425	0.0375	0.035	0.03	0.0275
SMD1206-010	0.148	1.32	0.116	0.10	0.085	0.075	0.07	0.06	0.055
SMD1206-010/33	0.148	1.32	0.116	0.10	0.085	0.075	0.07	0.06	0.055
SMD1206-012	0.18	0.16	0.14	0.12	0.10	0.09	0.08	0.07	0.07
SMD1206-012/48	0.18	0.16	0.14	0.12	0.10	0.09	0.08	0.07	0.07
SMD1206-016	0.24	0.21	0.18	0.16	0.14	0.13	0.12	0.11	0.10
SMD1206-016/24	0.24	0.21	0.18	0.16	0.14	0.13	0.12	0.11	0.10
SMD1206-016/33	0.24	0.21	0.18	0.16	0.14	0.13	0.12	0.11	0.10
SMD1206-020	0.30	0.26	0.23	0.20	0.17	0.15	0.14	0.12	0.11
SMD1206-020/30	0.30	0.26	0.23	0.20	0.17	0.15	0.14	0.12	0.11
SMD1206-025	0.37	0.33	0.29	0.25	0.22	0.20	0.17	0.15	0.12
SMD1206-025/24	0.37	0.33	0.29	0.25	0.22	0.20	0.17	0.15	0.12
SMD1206-025/30	0.37	0.33	0.29	0.25	0.22	0.20	0.17	0.15	0.12
SMD1206-035	0.50	0.45	0.40	0.35	0.30	0.27	0.24	0.21	0.15
SMD1206-035/16	0.50	0.45	0.40	0.35	0.30	0.27	0.24	0.21	0.15
SMD1206-035/30	0.50	0.45	0.40	0.35	0.30	0.27	0.24	0.21	0.15
SMD1206-050	0.71	0.64	0.57	0.50	0.42	0.39	0.35	0.31	0.25
SMD1206-050/13.2	0.71	0.64	0.57	0.50	0.42	0.39	0.35	0.31	0.25
SMD1206-050/16	0.71	0.64	0.57	0.50	0.42	0.39	0.35	0.31	0.25
SMD1206-050/24	0.71	0.64	0.57	0.50	0.42	0.39	0.35	0.31	0.25
SMD1206-050/30	0.71	0.64	0.57	0.50	0.42	0.39	0.35	0.31	0.25
SMD1206-075	1.14	1.01	0.88	0.75	0.65	0.59	0.54	0.49	0.41
SMD1206-075/13.2	1.14	1.01	0.88	0.75	0.65	0.59	0.54	0.49	0.41
SMD1206-075/16	1.14	1.01	0.88	0.75	0.65	0.59	0.54	0.49	0.41
SMD1206-075/24	1.14	1.01	0.88	0.75	0.65	0.59	0.54	0.49	0.41
SMD1206-075/30	1.14	1.01	0.88	0.75	0.65	0.59	0.54	0.49	0.41
SMD1206-100	1.45	1.31	1.15	1.00	0.84	0.77	0.69	0.61	0.48
SMD1206-100/16	1.45	1.31	1.15	1.00	0.84	0.77	0.69	0.61	0.48
SMD1206-100/24	1.45	1.31	1.15	1.00	0.84	0.77	0.69	0.61	0.48
SMD1206-110	1.60	1.45	1.30	1.10	0.95	0.80	0.72	0.66	0.55
SMD1206-110/16	1.60	1.45	1.30	1.10	0.95	0.80	0.72	0.66	0.55
SMD1206-110/24	1.60	1.45	1.30	1.10	0.95	0.80	0.72	0.66	0.55
SMD1206-150	2.18	1.94	1.72	1.50	1.28	1.17	1.06	0.96	0.77
SMD1206-150/13.2	2.18	1.94	1.72	1.50	1.28	1.17	1.06	0.96	0.77
SMD1206-150/16	2.18	1.94	1.72	1.50	1.28	1.17	1.06	0.96	0.77
SMD1206-200	2.88	2.63	2.34	2.00	1.74	1.58	1.42	1.17	0.93
SMD1206-200/12	2.88	2.63	2.34	2.00	1.74	1.58	1.42	1.17	0.93
SMD1206-250	3.30	3.10	2.82	2.50	2.16	1.98	1.83	1.54	1.33
SMD1206-260	3.43	3.22	2.93	2.60	2.23	2.03	1.87	1.57	1.35
SMD1206-260/12	3.43	3.22	2.93	2.60	2.23	2.03	1.87	1.57	1.35
SMD1206-300	4.05	3.66	3.36	3.00	2.50	2.28	2.00	1.62	1.35
SMD1206-350	4.65	4.23	3.92	3.50	2.92	2.68	2.35	1.91	1.42

# DIMENSIONS

Type Number	Package Dimensions (mm)							Package Dimensions (in)						
	A		B		C		D	A		B		C		D
	min	max	min	max	min	max	min	min	max	min	max	min	max	min
SMD1206-005	3	3.6	1.5	1.9	0.6	1.2	0.15	0.118	0.142	0.059	0.075	0.024	0.047	0.004
SMD1206-010	3	3.6	1.5	1.9	0.6	1.2	0.15	0.118	0.142	0.059	0.075	0.024	0.047	0.004
SMD1206-010/33	3	3.6	1.5	1.9	0.6	1.2	0.15	0.118	0.142	0.059	0.075	0.024	0.047	0.004
SMD1206-012	3	3.6	1.5	1.9	0.6	1.2	0.15	0.118	0.142	0.059	0.075	0.024	0.047	0.004
SMD1206-012/48	3	3.6	1.5	1.9	0.6	1.2	0.15	0.118	0.142	0.059	0.075	0.024	0.047	0.004
SMD1206-016	3	3.6	1.5	1.9	0.4	1.0	0.15	0.118	0.142	0.059	0.075	0.016	0.039	0.004
SMD1206-016/24	3	3.6	1.5	1.9	0.4	1.0	0.15	0.118	0.142	0.059	0.075	0.016	0.039	0.004
SMD1206-016/33	3	3.6	1.5	1.9	0.4	1.0	0.15	0.118	0.142	0.059	0.075	0.016	0.039	0.004
SMD1206-020	3	3.6	1.5	1.9	0.4	1.0	0.15	0.118	0.142	0.059	0.075	0.016	0.039	0.004
SMD1206-020/30	3	3.6	1.5	1.9	0.4	1.0	0.15	0.118	0.142	0.059	0.075	0.016	0.039	0.004
SMD1206-025	3	3.6	1.5	1.9	0.4	1.0	0.15	0.118	0.142	0.059	0.075	0.016	0.039	0.004
SMD1206-025/24	3	3.6	1.5	1.9	0.4	1.0	0.15	0.118	0.142	0.059	0.075	0.016	0.039	0.004
SMD1206-025/30	3	3.6	1.5	1.9	0.4	1.0	0.15	0.118	0.142	0.059	0.075	0.016	0.039	0.004
SMD1206-035	3	3.6	1.5	1.9	0.35	0.8	0.15	0.118	0.142	0.059	0.075	0.014	0.031	0.004
SMD1206-035/16	3	3.6	1.5	1.9	0.35	0.8	0.15	0.118	0.142	0.059	0.075	0.014	0.031	0.004
SMD1206-035/30	3	3.6	1.5	1.9	0.40	0.9	0.15	0.118	0.142	0.059	0.075	0.016	0.035	0.004
SMD1206-050	3	3.6	1.5	1.9	0.35	0.8	0.15	0.118	0.142	0.059	0.075	0.014	0.031	0.004
SMD1206-050/13.2	3	3.6	1.5	1.9	0.35	0.8	0.15	0.118	0.142	0.059	0.075	0.014	0.031	0.004
SMD1206-050/16	3	3.6	1.5	1.9	0.35	0.8	0.15	0.118	0.142	0.059	0.075	0.014	0.031	0.004
SMD1206-050/24	3	3.6	1.5	1.9	0.50	1.0	0.15	0.118	0.142	0.059	0.075	0.020	0.039	0.004
SMD1206-050/30	3	3.6	1.5	1.9	0.50	1.0	0.15	0.118	0.142	0.059	0.075	0.020	0.039	0.004
SMD1206-075	3	3.6	1.5	1.9	0.35	0.8	0.15	0.118	0.142	0.059	0.075	0.014	0.031	0.004
SMD1206-075/13.2	3	3.6	1.5	1.9	0.50	1.0	0.15	0.118	0.142	0.059	0.075	0.020	0.039	0.004
SMD1206-075/16	3	3.6	1.5	1.9	0.50	1.0	0.15	0.118	0.142	0.059	0.075	0.020	0.039	0.004
SMD1206-075/24	3	3.6	1.5	1.9	0.50	1.0	0.15	0.118	0.142	0.059	0.075	0.020	0.039	0.004
SMD1206-075/30	3	3.6	1.5	1.9	0.50	1.0	0.15	0.118	0.142	0.059	0.075	0.020	0.039	0.004
SMD1206-100	3	3.6	1.5	1.9	0.35	0.8	0.15	0.118	0.142	0.059	0.075	0.014	0.031	0.004
SMD1206-100/16	3	3.6	1.5	1.9	0.50	1.0	0.15	0.118	0.142	0.059	0.075	0.020	0.039	0.004
SMD1206-100/24	3	3.6	1.5	1.9	0.50	1.0	0.15	0.118	0.142	0.059	0.075	0.020	0.039	0.004
SMD1206-150	3	3.6	1.5	1.9	0.50	1.0	0.15	0.118	0.142	0.059	0.075	0.020	0.039	0.004
SMD1206-150/13.2	3	3.6	1.5	1.9	0.50	1.0	0.15	0.118	0.142	0.059	0.075	0.020	0.039	0.004
SMD1206-150/16	3	3.6	1.5	1.9	0.50	1.0	0.15	0.118	0.142	0.059	0.075	0.020	0.039	0.004
SMD1206-200	3	3.6	1.5	1.9	0.50	1.0	0.15	0.118	0.142	0.059	0.075	0.020	0.039	0.004
SMD1206-200/12	3	3.6	1.5	1.9	0.50	1.0	0.15	0.118	0.142	0.059	0.075	0.020	0.039	0.004
SMD1206-250	3	3.6	1.5	1.9	0.50	1.0	0.15	0.118	0.142	0.059	0.075	0.020	0.039	0.004
SMD1206-260	3	3.6	1.5	1.9	0.50	1.0	0.15	0.118	0.142	0.059	0.075	0.020	0.039	0.004
SMD1206-260/12	3	3.6	1.5	1.9	0.50	1.0	0.15	0.118	0.142	0.059	0.075	0.020	0.039	0.004
SMD1206-300	3	3.6	1.5	1.9	0.50	1.0	0.15	0.118	0.142	0.059	0.075	0.020	0.039	0.004
SMD1206-350	3	3.6	1.5	1.9	0.50	1.0	0.15	0.118	0.142	0.059	0.075	0.020	0.039	0.004

## PARAMETER CHARACTERISTIC CURVE

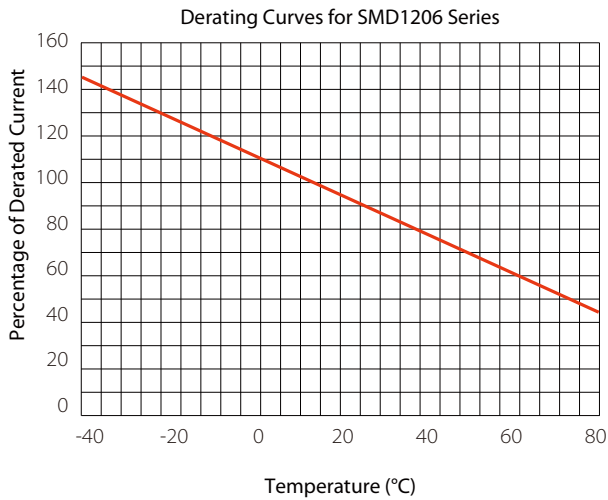
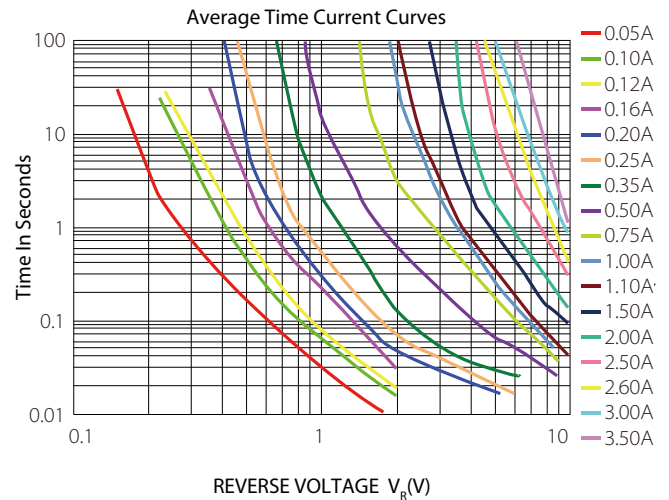
**FIG.1: Thermal Derating Curve**

**FIG.2: Average Time-Current Curve**

## REFLOW PROFILE

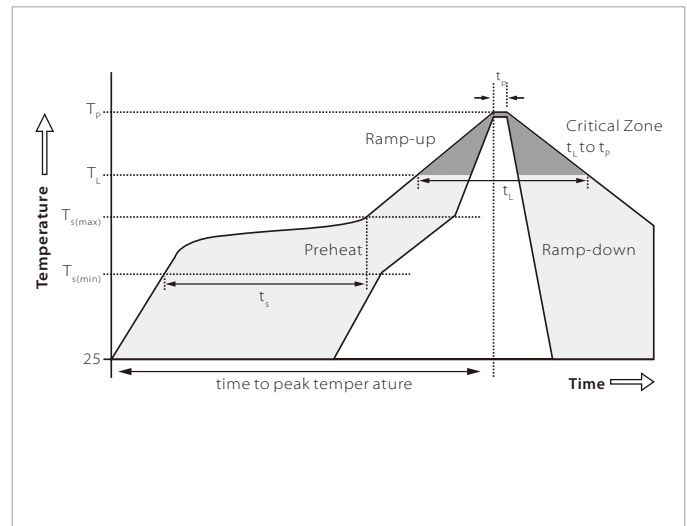
Reflow Condition		Pb-Free assembly
Pre Heat	Temperature Min	150°C
	Temperature Max	200°C
	Time(min to max)	60-180 secs
Average ramp up rate (Liquidus)Temp ( $T_L$ ) to peak		3°C/second max
$T_s$ (max)to $T_L$ - Ramp-up Rate		
Reflow	Temperature ( $T_L$ ) (Liquidus)	217°C
	Temperature ( $T_L$ )	60-150 seconds
Peak Temperature ( $T_p$ )		260+0/-5 °C
Time within 5°C of actual peak Temperature (tp)		20~40 seconds
Ramp-down Rate		6°C/second max
Time 25°C to peak Temperature ( $T_p$ )		8 minutes max.
Do not exceed		260°C

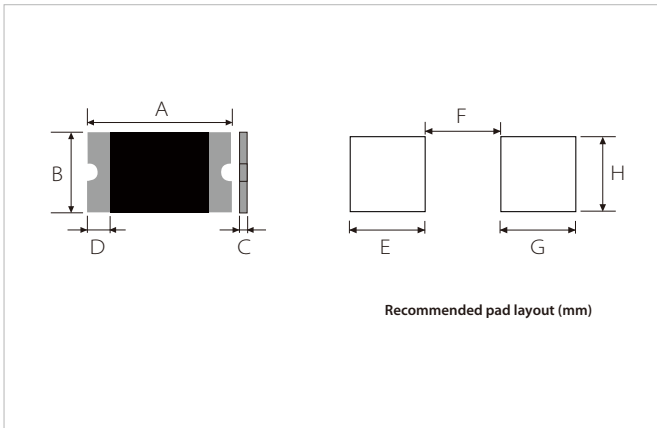

## PACKAGE MECHANICAL DATA



Ref.	Dimensions	
	Millimeters	
A	See Dimensions Table	
B		
C		
D		
E	1.0	
F	2.0	
G	1.0	
H	2.0	

## TAPING AND REEL SPECIFICATIONS

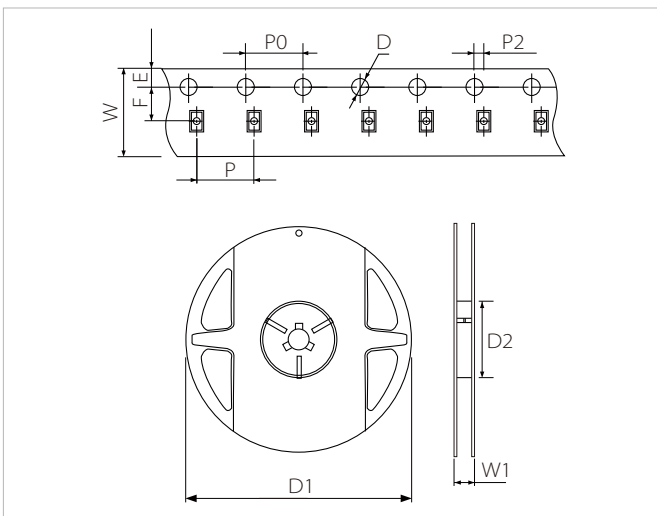

Symbol	Dimensions	
	Millimeters	Inches
W	8.15±0.3	0.321±0.012
P	4.0±0.1	0.157±0.004
P0	4.0±0.1	0.157±0.004
P2	2.0±0.05	0.079±0.002
F	3.5±0.05	0.138±0.002
E	1.75±0.1	0.069±0.004
D	1.55±0.05	0.061±0.002
D1(max)	178	7.007
D2(min)	60	2.362
W1	9.0±0.5	0.354±0.02

## ORDERING INFORMATION

Part Number	QTY/Reel	Reel Size
SMD1206-016 ,020,020/30, 025,035,035/16, 050,075,100,110	5000PCS	7"
Other	3500PCS	

**Headquarters**

No.3387 Shendu Road Pujiang  
I&E Park  
Minhang Shanghai China  
201000

**Hotline**

400-021-5756

**Web**

<https://www.semiware.com>

**Sales Center**

Tel: 86-21-3463-7458  
Email: [sales18@semiware.com](mailto:sales18@semiware.com)

**Customer Service**

Tel: 86-21-5484-1001  
Email: [sales17@semiware.com](mailto:sales17@semiware.com)

**Technical Support**

Tel: 86-21-3463-7654  
Email: [fae01@semiware.com](mailto:fae01@semiware.com)

**Complaint & Suggestions**

Tel: 86-21-3463-7172  
Ext: 8868  
Email: [cs03@semiware.com](mailto:cs03@semiware.com)

**By QR Code**

Website



Wechat

To find your local partner within Semiware's global network: [www.semiware.com](http://www.semiware.com)

© 2022 Semiware Semiconductor Inc.

The content of this document has been carefully checked and understood. However, neither Semiware nor its subsidiaries assume any liability whatsoever for any errors or inaccuracies of this document and the consequences thereof. Published specifications are subject to change without notice. Product suitability for any area of application must ultimately be determined by the customer. In all cases, products must never be operated outside their published specifications. Semiware does not guarantee the availability of all published products. This disclaimer shall be governed by substantive Swiss law and resulting disputes shall be settled by the courts at the place of business of Semiware. Latest publications and a complete disclaimer can be downloaded from the Semiware website. All trademarks recognized.