

## DESCRIPTION

- The 2SC4226 is a low supply voltage transistor designed for VHF, UHF low noise amplifier
- It is suitable for a high density surface mount assembly since the transistor has been applied small mini mold package



SOT-323

## FEATURES

- Low Noise NF = 1.2 dB TYP. @ f = 1 GHz,  $V_{CE} = 3\text{ V}$ ,  $I_C = 7\text{ mA}$
- High Gain  $|S_{21e}|^2 = 9.0\text{ dB}$  TYP. @ f = 1 GHz,  $V_{CE} = 3\text{ V}$ ,  $I_C = 7\text{ mA}$
- Small Mini Mold Package EIAJ: SC-70

## APPROVALS

<b>RoHS</b>	Compliance with 2011/65/EU
<b>HF</b>	Compliance with IEC61249-2-21:2003

## ABSOLUTE MAXIMUM RATINGS

Parameter	Symbol	Value	Unit
Collector to Base Voltage	$V_{CBO}$	20	V
Collector to Emitter Voltage	$V_{CEO}$	12	V
Emitter to Base Voltage	$V_{EBO}$	3	V
Collector Current	$I_C$	100	mA
Total Power Dissipation	$P_T$	150	mW
Junction Temperature	$T_J$	150	°C
Storage Temperature	$T_{STG}$	-65 to +150	°C

## ELECTRICAL CHARACTERISTICS( $T_A=25^{\circ}\text{C}$ )

Parameter	Test Condition	Symbol	Min.	Typ.	Max.	Unit
Collector Cutoff Current	$V_{CB}=10\text{V}, I_E=0$	$I_{CBO}$			1.0	$\mu\text{A}$
Emitter Cutoff Current	$V_{EB}=1\text{V}, I_C=0$	$I_{EBO}$			1.0	$\mu\text{A}$
DC Current Gain	$V_{CE}=3\text{V}, I_C=7\text{mA}^{*1}$	$h_{FE}$	40	110	250	V
Gain Bandwidth Product	$V_{CE}=3\text{V}, I_C=7\text{mA}$	$f_T$	3.0	4.5		GHz
Feed back Capacitance	$V_{CE}=3\text{V}, I_E=0, f=1\text{MHz}^{*2}$	$C_{re}$		0.7	1.5	pF
Insertion Power Gain	$V_{CE}=3\text{V}, I_C=7\text{mA}, f=1\text{GHz}$	$ S_{21e} ^2$	7	9		dB
Noise Figure	$V_{CE}=3\text{V}, I_C=7\text{mA}, f=1\text{GHz}$	NF		1.2	2.5	dB

\*1 Pulse Measurement ;  $PW \leq 350\ \mu\text{s}$ , Duty Cycle  $\leq 2\%$  Pulsed.

\*2 Measured with 3 terminals bridge, Emitter and Case should be grounded

## $h_{FE}$ CLASSIFICATION

Rank	R23	R24	R25
Marking	R23	R24	R25
hFE	40 to 80	70 to 140	125 to 250

## S-PARAMETER

V <sub>CE</sub> = 3V, I <sub>C</sub> = 7mA, Z <sub>o</sub> = 50Ω								
Frequency	S <sub>11</sub>		S <sub>21</sub>		S <sub>12</sub>		S <sub>22</sub>	
MHz	MAG	ANG	MAG	ANG	MAG	ANG	MAG	ANG
100.00	.750	-45.7	11.858	144.0	.035	63.3	.816	-28.5
200.00	.618	-84.9	10.093	122.3	.053	53.2	.609	-41.8
300.00	.528	-114.5	8.219	107.7	.064	50.6	.481	-46.7
400.00	.483	-134.3	6.684	97.9	.073	50.6	.411	-49.1
500.00	.459	-148.5	5.565	90.5	.081	50.7	.365	-50.5
600.00	.447	-158.8	4.737	84.6	.089	52.3	.337	-51.5
700.00	.441	-167.4	4.134	79.7	.098	53.5	.316	-52.6
800.00	.439	-174.4	3.653	75.2	.107	54.2	.300	-54.2
900.00	.437	179.2	3.283	71.1	.117	54.9	.290	-55.9
1000.00	.437	173.7	2.978	67.2	.126	55.6	.281	-57.9
1100.00	.440	168.6	2.732	63.7	.136	55.8	.275	-59.6
1200.00	.443	163.9	2.533	60.0	.147	55.3	.270	-62.3
1300.00	.444	159.6	2.357	56.6	.158	55.4	.267	-64.7
1400.00	.449	155.5	2.216	53.4	.169	55.3	.264	-67.5
1500.00	.450	151.6	2.077	50.3	.180	54.7	.259	-70.6
1600.00	.455	147.9	1.972	47.4	.192	54.5	.258	-73.3
1700.00	.459	144.3	1.868	44.3	.202	53.9	.256	-76.3
1800.00	.462	140.9	1.789	41.3	.214	53.0	.255	-79.6
1900.00	.466	137.5	1.702	38.4	.226	52.3	.253	-83.0
2000.00	.470	134.4	1.635	36.1	.238	51.5	.253	-86.4

V <sub>CE</sub> = 3V, I <sub>C</sub> = 7mA, Z <sub>o</sub> = 50Ω								
Frequency	S <sub>11</sub>		S <sub>21</sub>		S <sub>12</sub>		S <sub>22</sub>	
MHz	MAG	ANG	MAG	ANG	MAG	ANG	MAG	ANG
100.00	.819	-38.9	8.934	148.0	.038	65.8	.868	-23.6
200.00	.701	-73.4	8.007	127.6	.060	53.1	.687	-36.7
300.00	.608	-102.3	6.898	112.6	.072	47.6	.560	-42.4
400.00	.549	-123.6	5.819	101.8	.079	45.2	.483	-45.4
500.00	.511	-139.6	4.970	93.5	.086	45.7	.434	-47.2
600.00	.494	-151.0	4.255	86.9	.093	46.5	.402	-48.6
700.00	.481	-160.8	3.750	81.4	.099	47.2	.379	-49.9
800.00	.475	-168.6	3.328	76.3	.107	48.9	.361	-51.5
900.00	.472	-175.7	3.004	72.0	.113	49.7	.350	-53.4

$V_{CE}=3V, I_C=7mA, Z_0=50\Omega$								
Frequency	$S_{11}$		$S_{21}$		$S_{12}$		$S_{22}$	
MHz	MAG	ANG	MAG	ANG	MAG	ANG	MAG	ANG
1000.00	.471	178.2	2.734	67.7	.122	50.9	.340	-55.4
1100.00	.473	172.8	2.522	64.0	.130	51.6	.332	-57.3
1200.00	.474	167.6	2.355	60.2	.139	52.3	.328	-59.7
1300.00	.474	162.9	2.176	56.7	.148	53.1	.322	-62.3
1400.00	.477	158.4	2.038	53.2	.158	53.3	.319	-65.2
1500.00	.481	154.4	1.921	49.8	.168	53.7	.315	-68.2
1600.00	.484	150.3	1.818	46.7	.177	53.3	.313	-70.9
1700.00	.489	146.5	1.726	43.9	.190	53.3	.312	-73.9
1800.00	.490	142.9	1.647	40.6	.200	53.0	.312	-77.2
1900.00	.495	139.3	1.578	37.6	.212	52.7	.309	-80.8
2000.00	.501	136.0	1.505	35.0	.223	52.0	.309	-84.0

$V_{CE}=3V, I_C=3mA, Z_0=50\Omega$								
Frequency	$S_{11}$		$S_{21}$		$S_{12}$		$S_{22}$	
MHz	MAG	ANG	MAG	ANG	MAG	ANG	MAG	ANG
100.00	.899	-30.6	5.578	153.7	.042	69.0	.923	-17.3
200.00	.808	-60.6	5.327	134.4	.069	54.5	.793	-29.2
300.00	.723	-86.7	4.877	119.6	.084	46.0	.679	-35.4
400.00	.660	-108.2	4.341	108.1	.093	41.1	.604	-39.5
500.00	.610	-125.9	3.883	98.5	.098	38.8	.550	-42.0
600.00	.583	-138.6	3.388	90.9	.102	37.4	.513	-44.2
700.00	.560	-150.0	3.046	84.3	.106	37.8	.487	-45.9
800.00	.547	-159.4	2.741	78.5	.108	38.1	.468	-47.9
900.00	.538	-167.4	2.498	73.4	.112	39.5	.455	-49.9
1000.00	.535	-174.4	2.287	68.9	.116	41.0	.444	-52.3
1100.00	.534	179.3	2.111	64.6	.120	43.0	.435	-54.7
1200.00	.533	173.4	1.965	60.2	.125	45.1	.429	-57.2
1300.00	.533	168.3	1.830	56.3	.131	46.7	.424	-59.9
1400.00	.534	163.2	1.721	52.7	.139	48.3	.422	-62.8
1500.00	.538	158.7	1.620	49.2	.146	49.8	.417	-65.7
1600.00	.542	154.3	1.544	45.7	.155	51.3	.414	-68.8
1700.00	.545	150.0	1.464	42.7	.164	52.4	.415	-72.0
1800.00	.548	146.1	1.396	39.5	.174	53.0	.412	-75.3
1900.00	.552	142.0	1.336	36.6	.187	53.7	.411	-78.8
2000.00	.556	138.3	1.280	33.6	.199	54.1	.411	-82.3

$V_{CE} = 3V, I_C = 1mA, Z_o = 50\Omega$ 

Frequency MHz	$S_{11}$		$S_{21}$		$S_{12}$		$S_{22}$	
	MAG	ANG	MAG	ANG	MAG	ANG	MAG	ANG
100.00	.967	-22.9	1.935	159.9	.045	74.0	.978	-9.2
200.00	.930	-45.8	1.968	143.1	.083	60.1	.931	-17.4
300.00	.884	-67.1	1.938	129.1	.108	48.9	.870	-23.2
400.00	.842	-85.9	1.827	117.2	.125	39.4	.822	-28.0
500.00	.801	-103.1	1.748	106.7	.134	32.6	.779	-31.9
600.00	.771	-117.0	1.576	97.4	.137	27.1	.749	-35.3
700.00	.742	-130.0	1.498	89.2	.137	22.9	.722	-38.4
800.00	.722	-141.2	1.403	81.9	.134	20.0	.702	-41.3
900.00	.706	-151.1	1.326	75.6	.129	18.5	.690	-44.4
1000.00	.695	-159.9	1.242	69.6	.124	17.8	.680	-47.4
1100.00	.689	-167.7	1.169	64.5	.118	18.1	.671	-50.4
1200.00	.685	-174.9	1.102	59.6	.112	19.8	.666	-53.6
1300.00	.681	178.7	1.030	55.3	.106	23.5	.660	-56.9
1400.00	.681	172.6	.979	50.9	.103	28.0	.658	-60.4
1500.00	.683	166.8	.925	47.2	.100	33.6	.654	-64.0
1600.00	.684	161.4	.884	43.6	.102	40.4	.651	-67.6
1700.00	.684	156.1	.842	40.4	.107	47.5	.651	-71.5
1800.00	.686	151.4	.804	37.3	.115	53.5	.649	-75.1
1900.00	.689	146.6	.773	34.6	.127	57.9	.646	-79.2
2000.00	.690	142.1	.738	32.3	.141	62.1	.646	-83.0

# CHARACTERISTIC CURVES

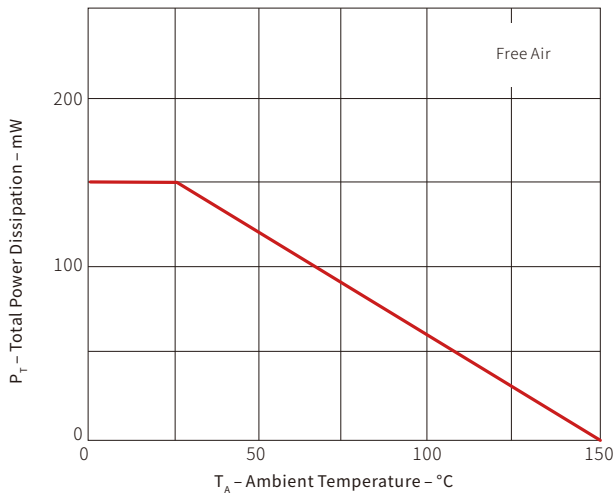
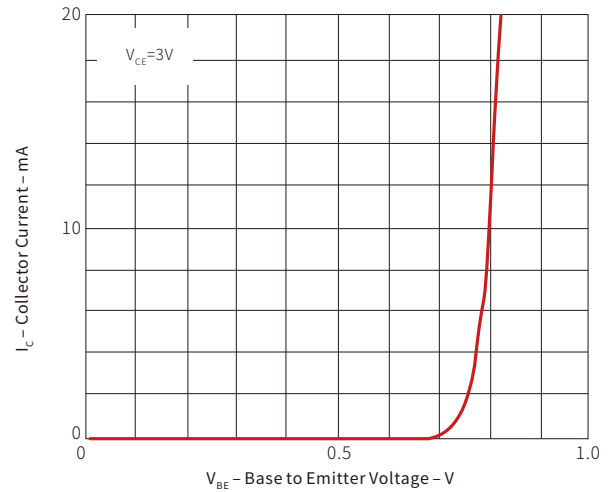
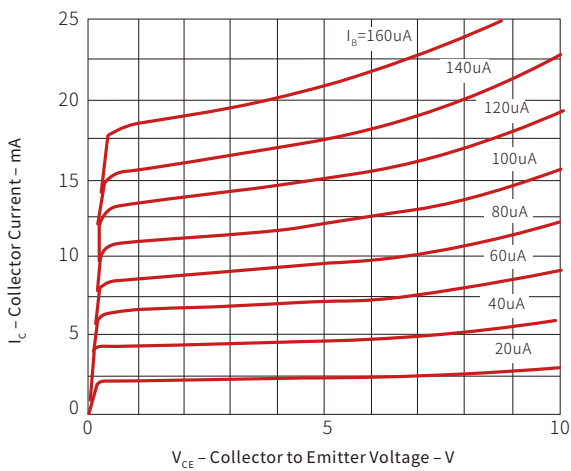
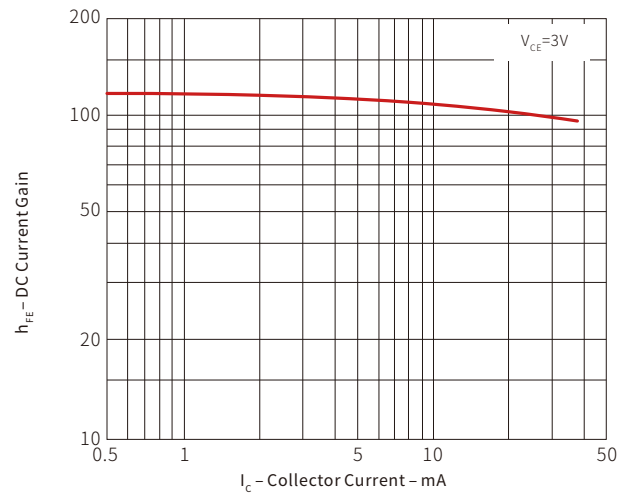
**Total Power Dissipation Vs. Ambient Temperature**

**Collector Current Vs. Base to Emitter Voltage**

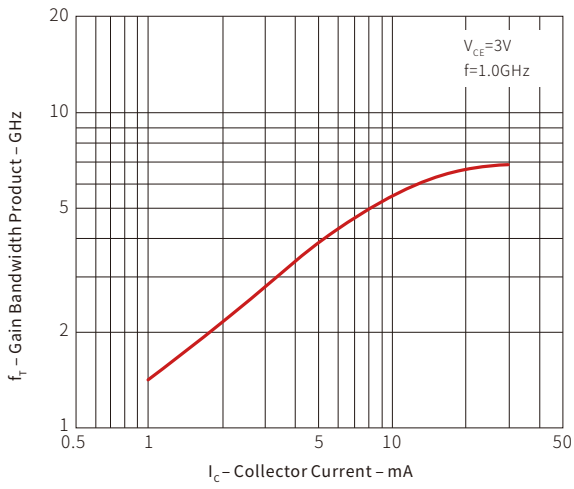
**Collector Current Vs. Collector to Emitter Voltage**

**Dc Current Gain Vs. Collector Current**

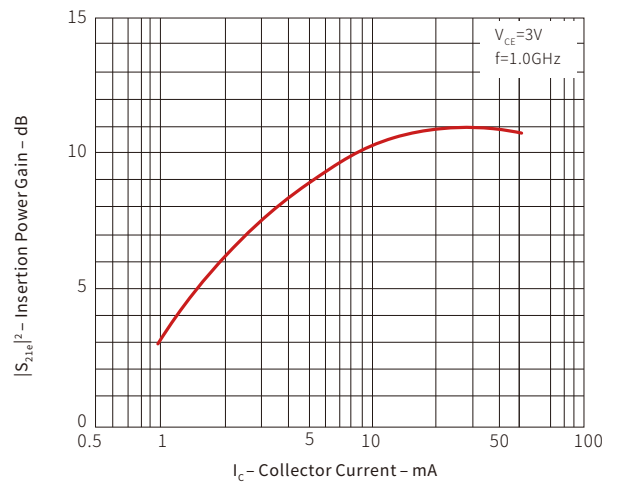
Gain Bandwidth Product Vs. Collector Current



Insertion Power Gain Vs. Collector Current



Noise Figure Vs. Collector Current

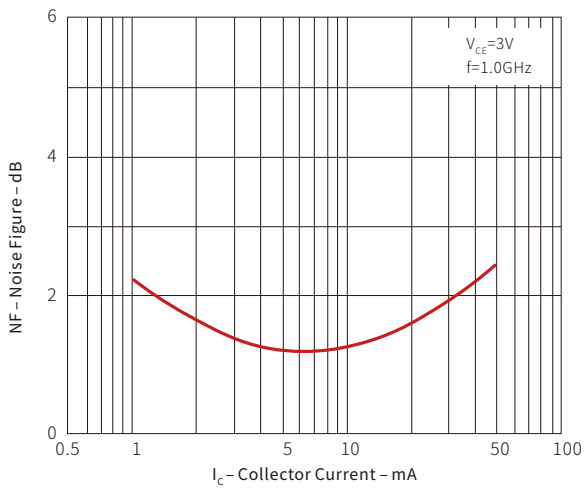

Insertion Power Gain Vs. Frequency

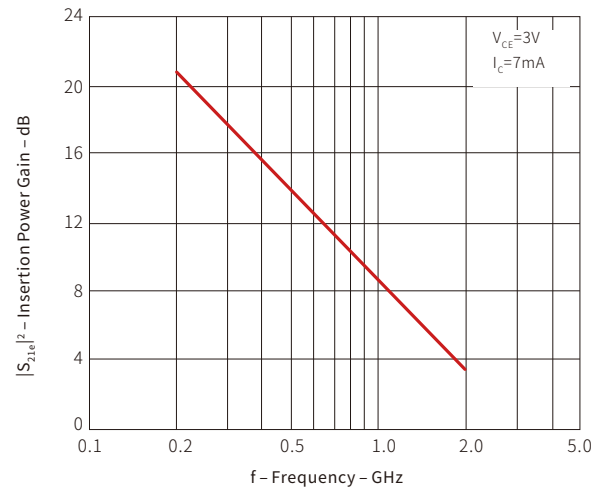

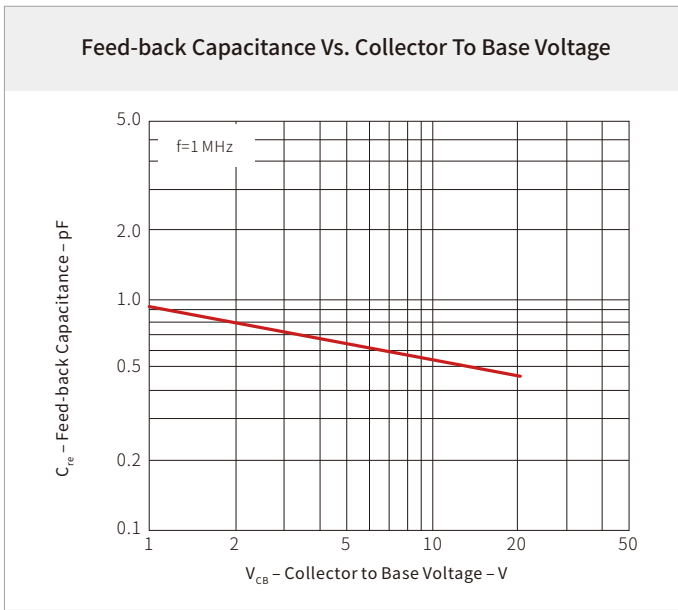

## SOLDERING PARAMETERS

Reflow Condition		Lead-free assembly
Pre Heat	Temperature Max ( $T_{s(min)}$ )	150°C
	Temperature Max ( $T_{s(max)}$ )	200°C
	Time (min to max) ( $t_s$ )	60 – 180 secs
Average ramp up rate (Liquidus Temp ( $T_L$ ) to peak)		3°C/second max
$T_{s(max)}$ to $T_L$ - Ramp-up Rate		3°C/second max
Reflow	Temperature ( $T_L$ ) (Liquidus)	217°C
	Time (min to max) ( $t_L$ )	60 – 150 seconds
Peak Temperature ( $T_p$ )		260°C
Time within 5°C of actual peak Temperature ( $t_p$ )		20 – 40 seconds
Ramp-down Rate		6°C/second max
Time 25°C to peak Temperature ( $T_p$ )		8 minutes max.
Do not exceed		260°C

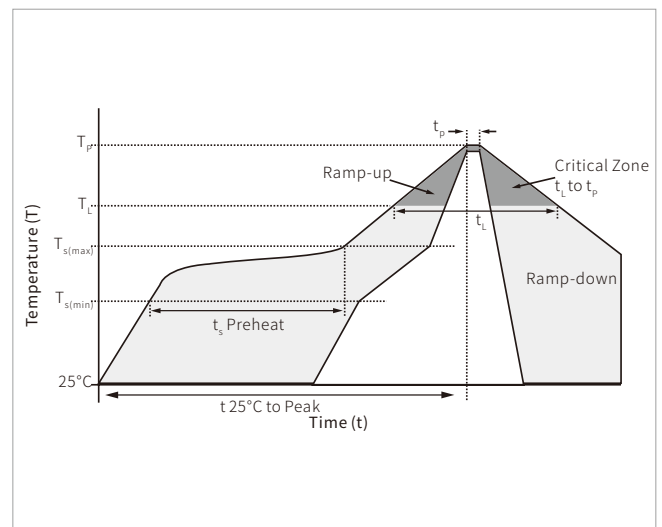



## SOT-323 PACKAGE INFORMATION

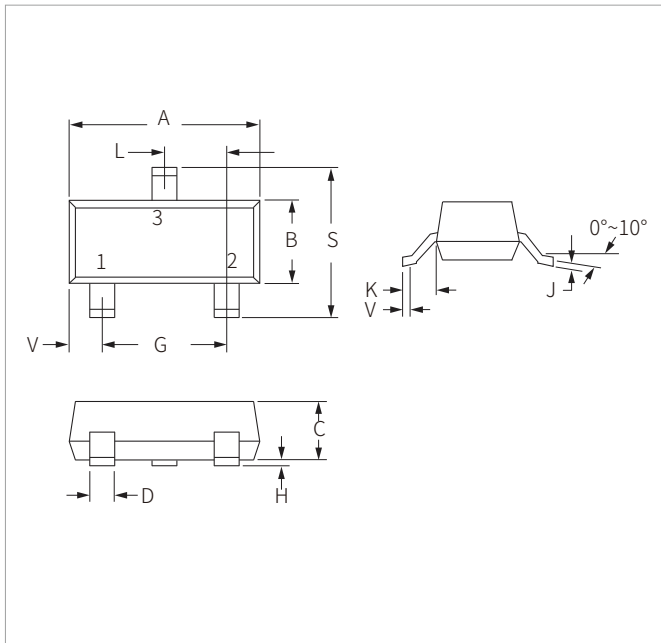

Ref.	Millimeters		Inches	
	Min.	Max.	Min.	Max.
A	2.00	2.20	0.079	0.087
B	1.15	1.35	0.045	0.053
C	0.90	1.00	0.035	0.039
D	0.20	0.40	0.008	0.016
G	1.20	1.40	0.047	0.055
H	0.00	0.10	0.000	0.004
J	0.08	0.15	0.003	0.006
K	0.525REF		0.021REF	
L	0.650TYP		0.026TYP	
S	2.15	2.45	0.085	0.096
V	0.26	0.46	0.010	0.018

## RECOMMENDED PAD LAYOUT DIMENSIONS

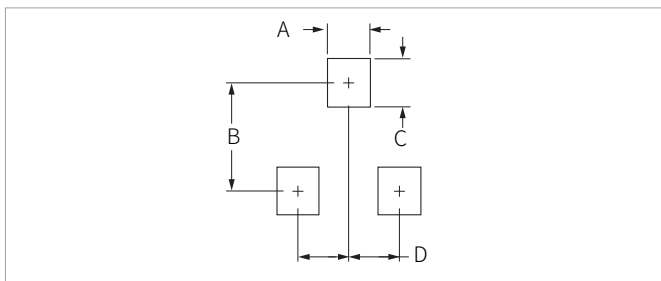

Ref.	Millimeters	Inches
	NOR	NOR
A	0.50	0.020
B	2.20	0.087
C	0.80	0.031
D	1.30	0.051

## ORDERING INFORMATION

Part Number	Component Package	QTY/Reel	Reel Size	Packing Style
2SC4226-T1	SOT-323	3000PCS	7"	Embossed tape 8 mm wide. Pin3 (Collector)face to perforation side of the tape
2SC4226-T2	SOT-323	3000PCS	7"	Embossed tape 8 mm wide. Pin1 (Emitter), Pin2 (Base) face to perforation side of the tape

**Headquarters**

No.3387 Shendu Road  
Pujiang I&E Park  
Minhang Shanghai China  
201000

**Hotline**

400-021-5756

**Web**

<https://www.semiware.com>

**Sales Center**

Tel: 86-21-3463-7458  
Email: [sales18@semiware.com](mailto:sales18@semiware.com)

**Customer Service**

Tel: 86-21-5484-1001  
Email: [sales17@semiware.com](mailto:sales17@semiware.com)

**Technical Support**

Tel: 86-21-3463-7654  
Email: [fae01@semiware.com](mailto:fae01@semiware.com)

**Complaint & Suggestions**

Tel: 86-21-3463-7172  
Ext: 8868  
Email: [cs03@semiware.com](mailto:cs03@semiware.com)

**By QR Code**

Website



Wechat

To find your local partner within Semiware's global website: [www.semiware.com](http://www.semiware.com)

© 2022 Semiware Semiconductor Inc.

The content of this document has been carefully checked and understood. However, neither Semiware nor its subsidiaries assume any liability whatsoever for any errors or inaccuracies of this document and the consequences thereof. Published specifications are subject to change without notice. Product suitability for any area of application must ultimately be determined by the customer. In all cases, products must never be operated outside their published specifications. Semiware does not guarantee the availability of all published products. This disclaimer shall be governed by substantive Chinese law and resulting disputes shall be settled by the courts at the place of business of Semiware. Latest publications and a complete disclaimer can be downloaded from the Semiware website. All trademarks recognized.