

FEATURES

- | Low Zener Impedance
- | Power Dissipation of 300mW
- | High Stability and High Reliability
- | Meet AEC-Q101 Requirements

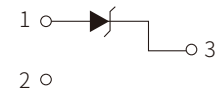

Schematic Symbol

MECHANICAL DATA

- | SOT-23 Small Outline Plastic Package
- | Epoxy UL: 94V-0
- | Mounting Position: Any

APPROVALS

RoHS	Compliance with 2011/65/EU
HF	Compliance with IEC61249-2-21:2003

MAXIMUM RATINGS (T_A=25°C)

Parameter	Symbol	Value	Unit
Power Dissipation	P _D	300	mW
Maximum forward voltage at I _F =10mA	V _F	0.9	V
Storage temperature range	T _S	-65 to +150	°C
Thermal resistance junction to ambient air Warmewider stand Sperrschicht –umgebende Luft	R _{θJA}	417	°C/W

ELECTRICAL CHARACTERISTICS

Part Number	Device Marking Code	Zener Voltage Range				Maximum Zener Impedance			Maximum Reverse Current	
		$V_Z@I_{ZT}$			I_{ZT}	$Z_{ZT}@I_{ZT}$	$Z_{ZK}@I_{ZK}$		I_R	V_R
		Nom(V)	Min(V)	Max(V)	(mA)	(Ω)	(mA)	(μ A)	(V)	
BZX84B2V4Q	Z11	2.4	2.35	2.45	5	100	600	1.0	50	1.0
BZX84B2V7Q	Z12	2.7	2.65	2.75	5	100	600	1.0	20	1.0
BZX84B3V0Q	Z13	3.0	2.94	3.06	5	95	600	1.0	10	1.0
BZX84B3V3Q	Z14	3.3	3.23	3.37	5	95	600	1.0	5	1.0
BZX84B3V6Q	Z15	3.6	3.53	3.67	5	90	600	1.0	5	1.0
BZX84B3V9Q	Z16	3.9	3.82	3.98	5	90	600	1.0	3	1.0
BZX84B4V3Q	Z17	4.3	4.21	4.39	5	90	600	1.0	3	1.0
BZX84B4V7Q	Z1	4.7	4.61	4.79	5	80	500	1.0	3	2.0
BZX84B5V1Q	Z2	5.1	5.00	5.20	5	60	480	1.0	2	2.0
BZX84B5V6Q	Z3	5.6	5.49	5.71	5	40	400	1.0	1	2.0
BZX84B6V2Q	Z4	6.2	6.08	6.32	5	10	150	1.0	3	4.0
BZX84B6V8Q	Z5	6.8	6.66	6.94	5	15	80	1.0	2	4.0
BZX84B7V5Q	Z6	7.5	7.35	7.65	5	15	80	1.0	1	5.0
BZX84B8V2Q	Z7	8.2	8.04	8.36	5	15	80	1.0	0.7	5.0
BZX84B9V1Q	Z8	9.1	8.92	9.28	5	15	100	1.0	0.5	6.0
BZX84B10Q	Z9	10	9.80	10.20	5	20	150	1.0	0.2	7.0
BZX84B11Q	Y1.	11	10.78	11.22	5	20	150	1.0	0.1	8.0
BZX84B12Q	Y2.	12	11.76	12.24	5	25	150	1.0	0.1	8.0
BZX84B13Q	Y3	13	12.74	13.26	5	30	170	1.0	0.1	8.0
BZX84B15Q	Y4	15	14.70	15.30	5	30	200	1.0	0.1	10.5
BZX84B16Q	Y5	16	15.68	16.32	5	40	200	1.0	0.1	11.2
BZX84B18Q	Y6.	18	17.64	18.36	5	45	225	1.0	0.1	12.6
BZX84B20Q	Y7	20	19.60	20.40	5	55	225	1.0	0.1	14.0
BZX84B22Q	Y8	22	21.56	22.44	5	55	250	1.0	0.1	15.4
BZX84B24Q	Y9	24	23.52	24.48	5	70	250	1.0	0.1	16.8
BZX84B27Q	Y10	27	26.46	27.54	5	80	300	0.5	0.1	18.9
BZX84B30Q	Y11.	30	29.40	30.60	5	80	300	0.5	0.1	21.0
BZX84B33Q	Y12	33	32.34	33.66	5	80	325	0.5	0.1	23.1
BZX84B36Q	Y13	36	35.28	36.72	5	90	350	0.5	0.1	25.2
BZX84B39Q	Y14	39	38.22	39.78	5	130	350	0.5	0.1	27.3

CHARACTERISTIC CURVES

Zener Characteristics (V_z 5.1V to 20 V)

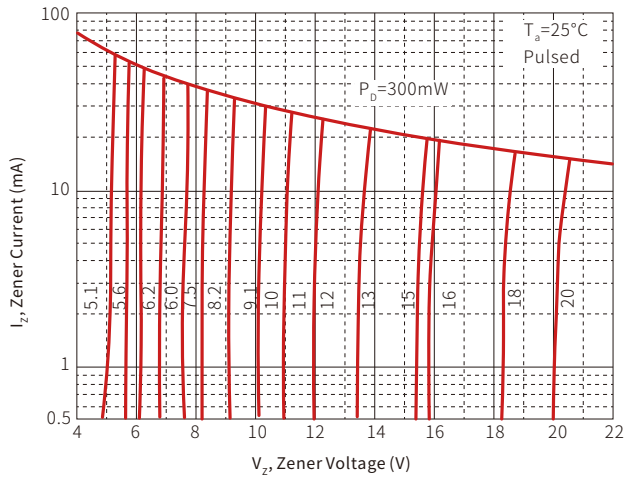

Temperature Coefficients

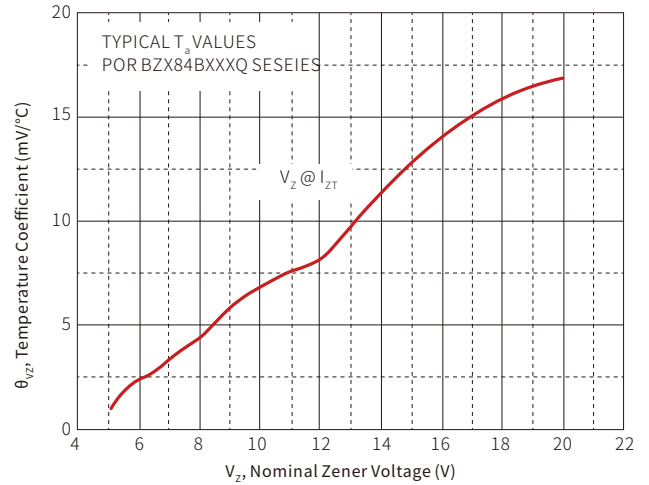

Typical Leakage Current

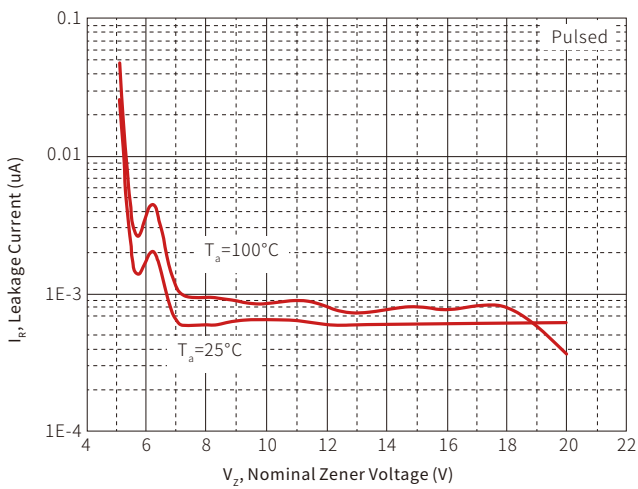

Typical Capacitance

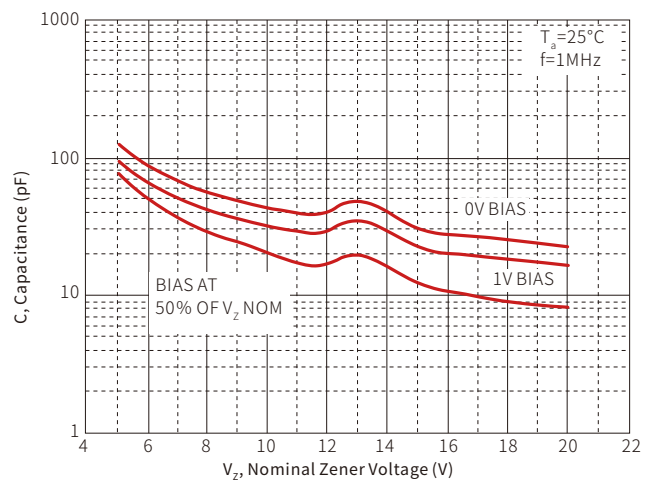

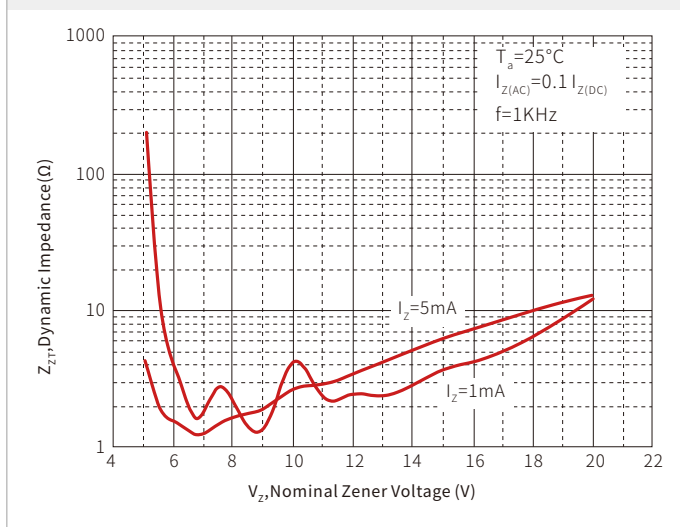
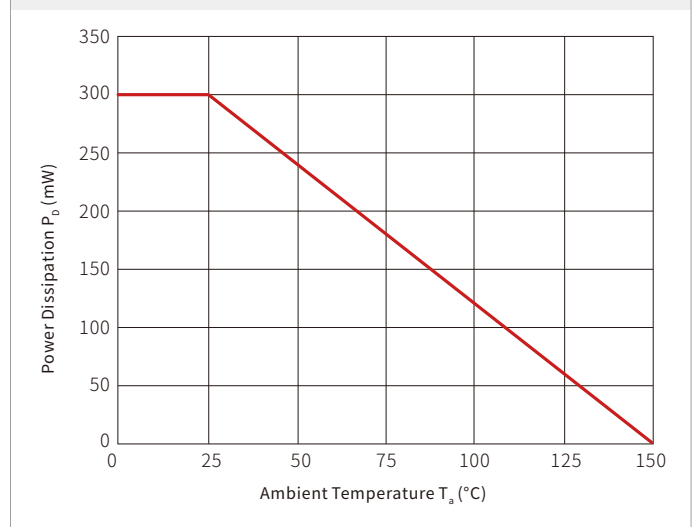
Effect of Zener Voltage on Zener Impedance

Power Derating Curve

SOLDERING PARAMETERS

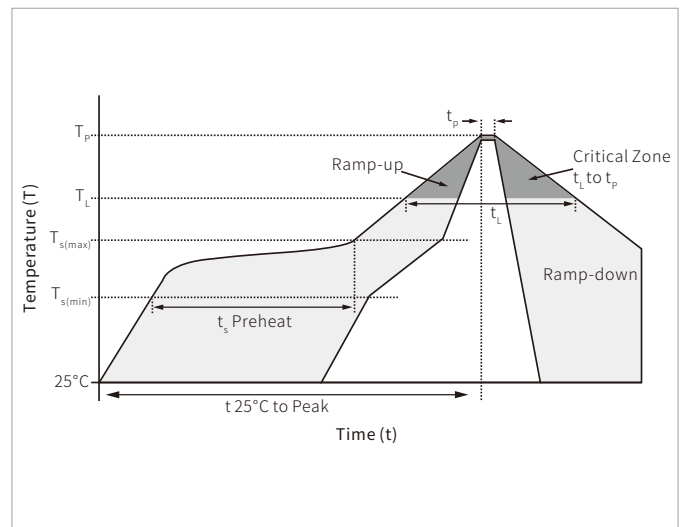
Reflow Condition		Lead-free assembly
Pre Heat	Temperature Max ($T_{s(min)}$)	150°C
	Temperature Max ($T_{s(max)}$)	200°C
	Time (min to max) (t_s)	60 – 180 secs
Average ramp up rate (Liquidus Temp (T_L) to peak)		3°C/second max
$T_{s(max)}$ to T_L - Ramp-up Rate		3°C/second max
Reflow	Temperature (T_L) (Liquidus)	217°C
	Time (min to max) (t_L)	60 – 150 seconds
Peak Temperature (T_p)		260°C
Time within 5°C of actual peak Temperature (t_p)		20 – 40 seconds
Ramp-down Rate		6°C/second max
Time 25°C to peak Temperature (T_p)		8 minutes max.
Do not exceed		260°C

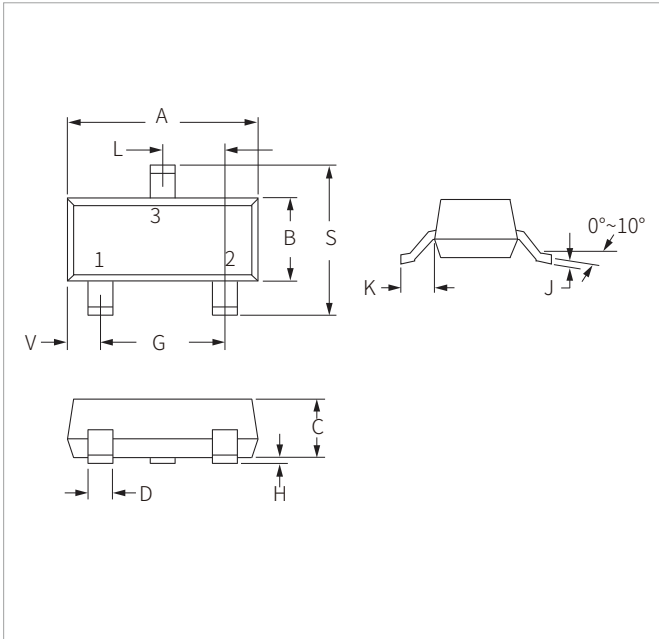

SOT-23 PACKAGE INFORMATION



Ref.	Millimeters		Inches	
	Min.	Max.	Min.	Max.
A	2.80	3.05	0.110	0.120
B	1.20	1.40	0.047	0.055
C	0.90	1.15	0.035	0.045
D	0.37	0.50	0.015	0.020
G	1.75	2.05	0.069	0.081
H	0.01	0.100	0.001	0.004
J	0.085	0.180	0.003	0.007
K	0.35	0.69	0.014	0.029
L	0.89	1.02	0.035	0.040
S	2.10	2.65	0.083	0.104
V	0.45	0.60	0.018	0.024

RECOMMENDED PAD LAYOUT DIMENSIONS

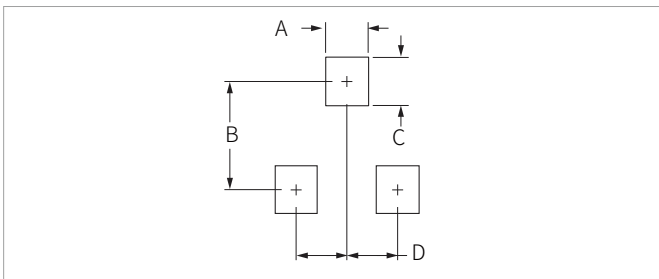

Ref.	Millimeters		Inches	
	Min.	Max.	Min.	Max.
A	0.71	0.97	0.028	0.038
B	1.88	2.13	0.074	0.084
C	0.71	0.97	0.028	0.038
D	0.81	1.07	0.032	0.042

ORDERING INFORMATION

Part Number	Component Package	QTY/Reel	Reel Size
BZX84B2V4Q-BZX84B39Q	SOT-23	3000PCS	7"

Headquarters

No.3387 Shendu Road
Pujiang I&E Park
Minhang Shanghai China
201000

Hotline

400-021-5756

Web

<https://www.semiware.com>

Sales Center

Tel: 86-21-3463-7458
Email: sales18@semiware.com

Customer Service

Tel: 86-21-5484-1001
Email: sales17@semiware.com

Technical Support

Tel: 86-21-3463-7654
Email: fae01@semiware.com

Complaint & Suggestions

Tel: 86-21-3463-7172
Ext: 8868
Email: cs03@semiware.com

By QR Code

Website



Wechat

To find your local partner within Semiware' s global website: www.semiware.com

© 2022 Semiware Semiconductor Inc.

The content of this document has been carefully checked and understood. However, neither Semiware nor its subsidiaries assume any liability whatsoever for any errors or inaccuracies of this document and the consequences thereof. Published specifications are subject to change without notice. Product suitability for any area of application must ultimately be determined by the customer. In all cases, products must never be operated outside their published specifications. Semiware does not guarantee the availability of all published products. This disclaimer shall be governed by substantive Chinese law and resulting disputes shall be settled by the courts at the place of business of Semiware. Latest publications and a complete disclaimer can be downloaded from the Semiware website. All trademarks recognized.