

FEATURES

- | High surge current handling capability
- | High energy absorption capability
- | Wide operating voltages ranging from 11Vrms to 460Vrms
- | Fast response time of less than 25ns, instantly clamping the transient over voltage
- | Low clamping voltages, providing better surge protection
- | Low capacitance values, providing digital switching circuitry protection
- | High insulation resistance, preventing electric arcing to the adjacent devices or circuits

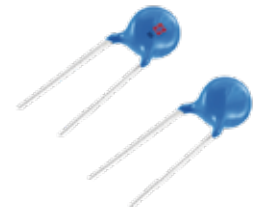

05D

APPLICATIONS

- | Surge protection of consumer equipment
- | Surge protection of communication, measuring and controller instrument
- | Surge protection in electronic home appliances, gas and petroleum appliances
- | Relay and electromagnetic valve surge absorption
- | Transistor, Diode, IC, Thyristor or Triac semiconductor protection

APPROVALS

RoHS	Compliance with 2011/65/EU
HF	Compliance with IEC61249-2-21:2003

GENERAL CHARACTERISTICS DEFINITION

- | Operating Temperature Range : -40°C ~ +85°C
- | Storage Temperature Range : -40°C ~ +125°C
- | Working Surface Temperature : +115°C
- | Insulation Resistance : >100MΩ

MATERIAL

- | Coating: Epoxy Resin
- | Lead Wire: The Copper Wire
- | Electrode: Silver Solder
- | Disk: Zinc Oxide

ELECTRICAL CHARACTERISTICS

Symbol		Mximum Allowable Voltage		Varistor Voltage @1mA	Mximum Clamping Voltage		Withstanding Surge Current (8/20μs)		Maximum Energy (10/1000μs)		Rated Power	Typical Capacitance (Reference)
Standard	High Surge	V _{AC} (V)	V _{DC} (V)	(V)	V _C (V)	I _p (A)	I(A) Standard	I(A) High Surge	(J) Standard	(J) High Surge	(W)	@1KHz (pF)
05D180L	05D180LJ	11	14	18(15-21)	38	1	100	250	0.4	0.6	0.01	1400
05D220K	05D220KJ	14	18	22(20-24)	43	1	100	250	0.6	0.7	0.01	1150
05D270K	05D270KJ	17	22	27(24-30)	53	1	100	250	0.7	0.9	0.01	930
05D330K	05D330KJ	20	26	33(30-36)	65	1	100	250	0.8	1.1	0.01	760
05D390K	05D390KJ	25	31	39(35-43)	77	1	100	250	1.1	1.2	0.01	640
05D470K	05D470KJ	30	38	47(42-52)	93	1	100	250	1.4	1.5	0.01	530
05D560K	05D560KJ	35	45	56(50-62)	110	1	100	250	1.5	1.8	0.01	450
05D680K	05D680KJ	40	56	68(61-75)	135	1	100	250	1.8	2.2	0.01	370
05D820K	05D820KJ	50	65	82(74-90)	135	5	400	800	2.6	3.8	0.1	300
05D101K	05D101KJ	60	85	100(90-110)	165	5	400	800	2.8	4.0	0.1	250
05D121K	05D121KJ	75	100	120(108-132)	200	5	400	800	4.2	5.0	0.1	210
05D151K	05D151KJ	95	125	150(135-165)	250	5	400	800	4.2	7.0	0.1	165
05D181K	05D181KJ	115	150	180(162-198)	300	5	400	800	5.6	8.0	0.1	140
05D201K	05D201KJ	130	170	200(185-225)	330	5	400	800	7.7	8.7	0.1	125
05D221K	05D221KJ	140	180	220(198-242)	360	5	400	800	8.8	9.0	0.1	110
05D241K	05D241KJ	150	200	240(216-262)	395	5	400	800	9.8	11.0	0.1	110
05D271K	05D271KJ	175	225	270(243-297)	455	5	400	800	10.5	13.0	0.1	95
05D301K	05D301KJ	190	250	300(270-330)	505	5	400	800	11.8	14.0	0.1	5
05D331K	05D331KJ	210	275	330(297-363)	550	5	400	800	14.0	14.5	0.1	75
05D361K	05D361KJ	230	300	360(324-396)	595	5	400	800	14.0	16.0	0.1	70
05D391K	05D391KJ	250	320	390(351-429)	650	5	400	800	15.4	17.0	0.1	65
05D431K	05D431KJ	275	350	430(387-473)	710	5	400	800	16.8	20.0	0.1	60
05D471K	05D471KJ	300	385	470(423-517)	775	5	400	800	18.2	20.8	0.1	55
05D511K	05D511KJ	320	415	510(459-561)	845	5	400	800	19.6	21.0	0.1	50
05D561K	05D561KJ	350	460	560(504-616)	920	5	400	800	19.6	23.0	0.1	45
05D621K	05D621KJ	385	505	620(558-682)	1025	5	400	800	21.0	25.0	0.1	40
05D681K	05D681KJ	420	560	680(612-748)	1120	5	400	800	21.0	29.0	0.1	35
05D751K	05D751KJ	460	615	750(675-825)	1240	5	400	800	22.4	32.0	0.1	30

CHARACTERISTIC CURVES

Items	Test condition/Description					
Varistor Voltage	The voltage across the varistor measured at 1 mA DC, can be called Vb					
Maximum Allowable Voltage	Maximum continuous sine wave(RMS) or DC voltage which may be applied					
Maximum Clamping Voltage	Peak voltage across the varistor with a specified peak impulse current of 8/20μs waveform					
Rated Power	The maximum average power that can be applied within the specified ambient temperature					
Withstanding Surge Current	The maximum current within the varistor voltage change of less than ±10% when one impulse current(8/20μs) applied					
Energy	The max.energy absorbed with a varistor voltage change of less than ± 10% when one impulse (10/1000μs) is applied					
Varistor Voltage Temperature Coefficient	$\left \frac{V_{b@85^{\circ}\text{C}} - V_{b@25^{\circ}\text{C}}}{V_{b@25^{\circ}\text{C}}} \times \frac{1}{60} \times 100\% \left(\%/^{\circ}\text{C} \right) \right \leq 0.05\% / ^{\circ}\text{C}$ $\left \frac{V_{b@-40^{\circ}\text{C}} - V_{b@25^{\circ}\text{C}}}{V_{b@25^{\circ}\text{C}}} \times \frac{1}{65} \times 100\% \left(\%/^{\circ}\text{C} \right) \right \leq 0.05\% / ^{\circ}\text{C}$					
Surge Life	The max.current with a varistor voltage change of less than ±10% when 10,000 times impulse current (8/20μs) are applied at intervals of 20 seconds at room temperature <table border="1" style="margin-left: auto; margin-right: auto;"> <tr> <td rowspan="2">05D Series</td> <td>180L to 680K</td> <td>10A(8/20μs)</td> </tr> <tr> <td>820K to 751K</td> <td>20A(8/20μs)</td> </tr> </table>	05D Series	180L to 680K	10A(8/20μs)	820K to 751K	20A(8/20μs)
05D Series	180L to 680K		10A(8/20μs)			
	820K to 751K	20A(8/20μs)				

CHARACTERISTIC CURVES

Items	Test condition/Description	Specifications															
High Temperature Storage	Ambient Temp:125±2°C Duration:1000 hrs	$ \Delta V_{1_{mA}} / V_{1_{mA}} \leq 5\%$															
Low Temperature Storage	Ambient Temp:-40±2°C Duration:1000 hrs	$ \Delta V_{1_{mA}} / V_{1_{mA}} \leq 5\%$															
Humidity	Ambient Temp:40±2°C,90~95% R.H. Duration:1000 hrs	$ \Delta V_{1_{mA}} / V_{1_{mA}} \leq 5\%$															
Temperature Cycle	The conditions shown below shall be repeated 5 cycles <table border="1" style="margin-left: auto; margin-right: auto;"> <thead> <tr> <th>Step</th> <th>Temperature(°C)</th> <th>Period(minutes)</th> </tr> </thead> <tbody> <tr> <td>1</td> <td>-40±3</td> <td>30±3</td> </tr> <tr> <td>2</td> <td>Room temperature</td> <td>15±3</td> </tr> <tr> <td>3</td> <td>125±3</td> <td>30±3</td> </tr> <tr> <td>4</td> <td>Room temperature</td> <td>15±3</td> </tr> </tbody> </table>	Step	Temperature(°C)	Period(minutes)	1	-40±3	30±3	2	Room temperature	15±3	3	125±3	30±3	4	Room temperature	15±3	No visible damage $ \Delta V_{1_{mA}} / V_{1_{mA}} \leq 5\%$
Step	Temperature(°C)	Period(minutes)															
1	-40±3	30±3															
2	Room temperature	15±3															
3	125±3	30±3															
4	Room temperature	15±3															
High Temperature Load	Ambient Temp:85±2°C ,Duration:1000 hrs Load:Max.Allowable Voltage in AC eara	$ \Delta V_{1_{mA}} / V_{1_{mA}} \leq 10\%$															
Damp Heat Load	Ambient Temp:40±2°C ,90~95% R.H. Duration:1000 hrs Load:Max.Allowable Voltage	No visible damage $ \Delta V_{1_{mA}} / V_{1_{mA}} \leq 10\%$															
Voltage Proof	Metal balls method,2500Vac 1 min	No visible damage															

WAVE SOLDERING

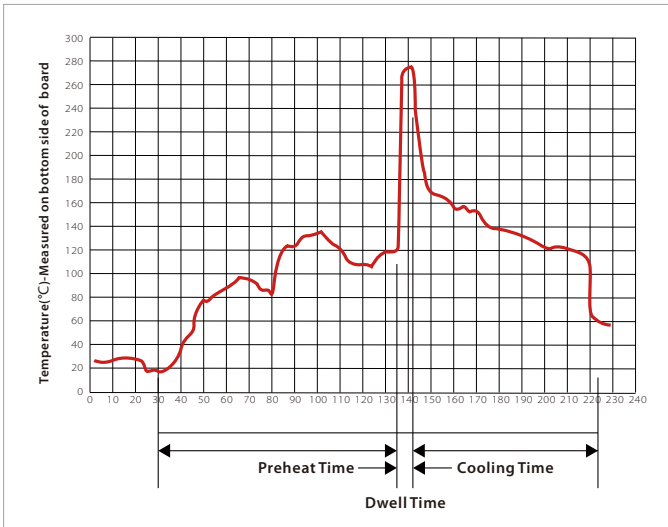

Wave Parameter		Lead-free assembly
Pre Heat	Temperature Min	100°C
	Temperature Max	150°C
	Time(min to max)	60 – 180 secs
Solder pot Temperature		280°C Max
Solder Dwell Time		2-5 seconds

PACKAGE INFORMATION

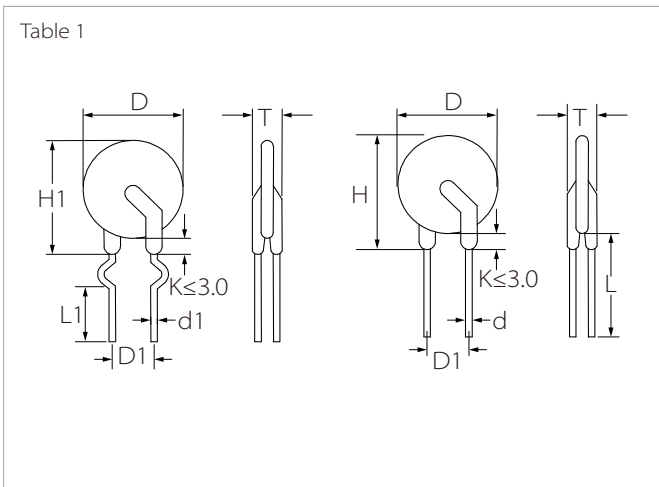

Symbol	Dimension(mm)
H(max)	12.0
H1(max)	13.0
L(min)	20.0
L1(min)	15.0
D(max)	7.0
D1(±0.8)	5.0
T(max)	Table2
d(±0.05)	0.6
d1(±0.4)	1.2

Table 2		Tmax(mm)					
05D180L	3.8	05D820K	4.1	05D271K	4.5	05D561K	6.2
05D220K	3.8	05D101K	4.3	05D301K	4.7	05D621K	6.4
05D270K	3.9	05D121K	4.5	05D331K	4.8	05D681K	6.4
05D330K	3.9	05D151K	4.8	05D361K	5.0	05D751K	6.5
05D390K	4.1	05D181K	4.1	05D391K	5.1		
05D470K	4.1	05D201K	4.1	05D431K	5.3		
05D560K	4.5	05D221K	4.2	05D471K	5.6		
05D680K	4.5	05D241K	4.3	05D511K	5.8		

ORDERING INFORMATION

Part Number	Component Package	Package
05D SERIES	05D	1000PCS

Headquarters

No.3387 Shendu Road Pujiang
I&E Park
Minhang Shanghai China
201000

Hotline

400-021-5756

Web

<https://www.semiware.com>

Sales Center

Tel: 86-21-3463-7458
Email: sales18@semiware.com

Customer Service

Tel: 86-21-5484-1001
Email: sales17@semiware.com

Technical Support

Tel: 86-21-3463-7654
Email: fae01@semiware.com

Complaint & Suggestions

Tel: 86-21-3463-7172
Ext: 8868
Email: cs03@semiware.com

By QR Code

Website



Wechat

To find your local partner within Semiware's global network: www.semiware.com

© 2022 Semiware Semiconductor Inc.

The content of this document has been carefully checked and understood. However, neither Semiware nor its subsidiaries assume any liability whatsoever for any errors or inaccuracies of this document and the consequences thereof. Published specifications are subject to change without notice. Product suitability for any area of application must ultimately be determined by the customer. In all cases, products must never be operated outside their published specifications. Semiware does not guarantee the availability of all published products. This disclaimer shall be governed by substantive Chinese law and resulting disputes shall be settled by the courts at the place of business of Semiware. Latest publications and a complete disclaimer can be downloaded from the Semiware website. All trademarks recognized.