

## FEATURES

- | Switching power-supply,switch power,ups power
- | Electronic energy saving lamps electronic ballast and all kinds of electric heater
- | All kinds of RT,display
- | Bulb and other lighting lamps



## CHARACTERISTIC

- | Small size,large power,strong capacity of suppression of inrush current
- | Fast response
- | Big material constant(B value),small residual resistance
- | Long life and high reliability
- | Complete series,wide applications

## APPROVALS

<b>RoHS</b>	Compliance with 2011/65/EU
<b>HF</b>	Compliance with IEC61249-2-21:2003

## TECHNICAL PARAMETERS

Part No	$R_{25}$ ( $\Omega$ )	Max.steady State current (A)	Residual Resistance ( $\Omega$ )	Dissipation factor (mW/ $^{\circ}$ C)	Thermal time Constant (s)	Operating Temperature ( $^{\circ}$ C)
5D-5	5	1	0.35	6	20	-40~+150
8D-5	8	0.7	0.77			
10D-5	10	0.7	0.77			
20D-5	20	0.5	0.997			
33D-5	33	0.5	1.88			
5D-7	5	2	0.28	9	30	-40~+150
8D-7	8	1	0.77			
10D-7	10	1	0.77			
12D-7	12	1	0.82			
16D-7	16	0.7	1.00			
20D-7	20	0.6	1.11			
22D-7	22	0.6	1.11			
33D-7	33	0.5	1.49			

Part No	R <sub>25</sub> (Ω)	Max.steady State current (A)	Residual Resistance (Ω)	Dissipation factor (mW/°C)	Thermal time Constant (s)	Operating Temperature (°C)
3D-9	3	4	0.12	11	35	-40~+175
5D-9	5	3	0.21			
6D-9	6	2	0.32			
8D-9	8	2	0.40			
10D-9	10	2	0.46			
12D-9	12	1	0.66			
15D-9	15	1	0.80			
16D-9	16	1	0.80			
20D-9	20	1	0.88			
22D-9	22	1	0.95			
33D-9	33	1	1.12			
50D-9	50	1	1.25			
100D-9	100	0.8	3.02			
120D-9	120	0.8	3.02			
2.5D-11	2.5	5	0.10	14	50	-40~+175
3D-11	3	5	0.10			
5D-11	5	4	0.16			
8D-11	8	3	0.25			
10D-11	10	3	0.28			
12D-11	12	2	0.46			
15D-11	15	2	0.47			
16D-11	16	2	0.47			
20D-11	20	2	0.51			
22D-11	22	2	0.56			
33D-11	33	1.5	0.67			
47D-11	47	1.5	1.02			
50D-11	50	1.5	1.22			
2.5D-13	2.5	6	0.088	15	68	-40~+200
3D-13	3	6	0.092			
4.7D-13	4.7	5	0.12			
5D-13	5	5	0.125			
8D-13	8	4	0.194			
10D-13	10	4	0.206			
16D-13	16	3	0.335			
18D-13	18	3	0.372			

Part No	R <sub>25</sub> (Ω)	Max.steady State current (A)	Residual Resistance (Ω)	Dissipation factor (mW/°C)	Thermal time Constant (s)	Operating Temperature (°C)
20D-13	20	3	0.372	15	68	-40~+200
30D-13	30	2.5	0.517			
47D-13	47	2	0.81			
1.5D-15	1.5	8	0.071	18	86	-40~+200
2.5D-15	2.5	8	0.071			
3D-15	3	7	0.075			
5D-15	5	6	0.112			
7D-15	7	5	0.173			
8D-15	8	5	0.178			
10D-15	10	5	0.18			
15D-15	15	4	0.268			
16D-15	16	4	0.268			
18D-15	18	4	0.288			
20D-15	20	4	0.288			
30D-15	30	3.5	0.438			
47D-15	47	3	0.68			
50D-15	50	3	0.72			
1.3D-20	1.3	9	0.037	24	113	-40~+200
1.5D-20	1.5	9	0.037			
2.5D-20	2.5	8	0.055			
3D-20	3	8	0.055			
5D-20	5	7	0.087			
8D-20	8	6	0.142			
10D-20	10	6	0.162			
16D-20	16	5	0.212			
20D-20	20	5	0.212			

## PARAMETERS OF TECHNOLOGY

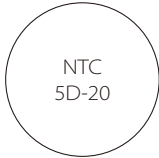
Marking		
	NTC	NTC thermistor
	5	5Ω
	D	Disk-Type
	20	19±1(mm)

## PARAMETERS OF TECHNOLOGY

1.	Zero Power Resistance at 25 °C (Ω)	5±20%
2.	Thermal Time Constant (S)	113
3.	Thermal Dissipation Constant (mW/°C)	24
4.	Operating Temperature (°C)	-40 ~ +200
5.	Max Steady State Current (A)	7
6.	Maximum allowable capacity value (240Vac)	1500uF
7.	Insulation resistance: 1000 MΩ ohm, the terminal of the thermistor connected as an electrode, metal foil as another electrode, 100V ± 15V DC voltage is applied between the two electrodes measure the insulation resistance between the two electrodes, the voltage applied to the time of 1 min, the insulation resistance of not less than 1000 MΩ	
8.	High voltage terminal: thermistor connected as an electrode, metal foil as another electrode in two electrode applied between a frequency of 40Hz-60Hz, AC voltage and insulation voltage of 1.4 times the provisions (AC500V) for the duration of the peak voltage, 60s + 5S, the rate of voltage should be similar to the 100V / s thermistor applied gradually, there should be no breakdown or arcing	
9.	B Value	2800±10%
Using the following formula $B = \left[ \frac{T_a \times T_b}{T_b - T_a} \right] \times \ln \left( \frac{R_a}{R_b} \right)$ or: $B = 2.303 \times \left[ \frac{T_a \times T_b}{T_b - T_a} \right] \times \log \left( \frac{R_a}{R_b} \right)$ $T_a = 298.15K$ $T_b = 358.15K$ <p>B value is the material coefficient or thermal index, B value is decided by the size of the material properties, allowing the + 5% tolerance range of B value, B value influence the size of the material properties; the B values are different, the residual resistance of different sizes, continuous working temperature rise is also different; the bigger the B value, the residual resistance is small when the temperature rise is small.</p>		

## PRINCIPLE OF THERMAL RESISTOR IS CHOSEN

1.	Thermistor maximum operating current > loop operating current
2.	Nominal resistance values of thermal resistance $R \geq 1.414 * E / I_m$ E is the line voltage I <sub>m</sub> a surge current In general, the switching power supply, switching power supplies, uninterruptible power supplies, power inverter and other times operating current I <sub>m</sub> = 100 For the filament heater circuit like I <sub>m</sub> = 30 times the operating current
3.	B The larger the value, the smaller the residual resistance, the smaller the temperature rise during operation.
4.	Thermal time constant and dissipation factor as both mutually dependent relationship, not to say that one or the greater the value, the better the smaller the better, but the product of the two greater the heat capacity of the thermistor greater, then resistance to surge current, the stronger
5.	When the power supply circuit for the thermistor is mainly used to suppress large inrush current at power-on, a large inrush current is the capacitor discharge, the filter to be installed in the tank circuit capacitance matching is a very critical condition to ensure that the thermistor circuit can play a role in security protection, so the power supply design requirements for manufacturers should also take full account of this factor.
6.	Through the circuit maximum operating voltage and maximum starting current and other parameters can use the formula $R = U / I$ calculated the resistance value range
7.	These principles may choose to lock the NTC thermistor corresponding model, if your company has special design needs with our technical department to discuss

## STORAGE CONDITION

1.	Temperature	-10 C ~ +40 C
	Humidity	≤70%RH
	Term	≤6 months(First-in/ First-out)
	Place	1.Do not exposing the components to the following conditions, otherwise, it may result in deterioration of characteristics 2.Corrosive gas or deoxidizing gas 3.Flammable and explosive gases 4.Oil, water and chemical liquid 5.Under the sunlight
2.	Do not apply the components under the following conditions, otherwise, it may result in deterioration of characteristics, destruction of components or in the worst case, to catching fire	
3.	Exceeding I <sub>max</sub>	
4.	Exceeding rated temperature range	
5.	Inferior thermal dissipation, Due to badly inferior thermal dissipation, some part of the components body will become overheated and then be damaged	

## PROPERTIES OF PRODUCTS

Item	Specification	Test Conditions & Methods
Solder-ability	Surface area of tin ≥ 95%	260±3 C、3±0.3sec
Resistance To Soldering Heat	No visible mechanical damage. $\Delta R/R_N \leq 20\%$ ( $\Delta R =  R'_N - R_N $ )	265±3 C、10±1sec
Strength of lead terminal	No break out $\Delta R/R_N \leq 20\%$ ( $\Delta R =  R'_N - R_N $ )	Horizontal tension (10±1 Sec pull at the end of both conductors in horizontal direction) Lead line diameter (mm)    Tension (kg) 0.5 < d ≤ 0.8                    1.0 0.8 < d ≤ 1.25                   2.0
Free fall	$\Delta R/R_N \leq 10\%$ ( $\Delta R =  R'_N - R_N $ )	NTC thermistor fell vertically from 1 m to cement floor 3 times, and recovered 5 min at room temperature after test
Vibration	$\Delta R/R_N \leq 10\%$ ( $\Delta R =  R'_N - R_N $ )	The frequency range : 10 Hz-500Hz, Amplitude : 0.75 mm 2 vibrations in each h three directions
High temperature storage	$\Delta R/R_N \leq 20\%$	Tu±5 C、1000±24hrs
Low temperature storage	$\Delta R/R_N \leq 20\%$	TL±5 C、1000±24hrs
Rated Zero-Power Resistance RN (Ω)	5±20%	Ambient temp. Range: 25°C±1°C(T <sub>A</sub> ). Testing voltage: 1.5VDC After placing for 1~2 hours under T <sub>A</sub> , the resistance value shall be measured
Thermal Dissipation Constant	≥24	The thermal dissipation constant(δ) could be calculated by the ratio of a change in power dissipation(ΔP) of the thermistor to a change in temperature(ΔT) of the thermistor at a specified ambient temperature
Thermal Time Constant	≤113	The time(τ) shall be measured within which the temperature change of NTC thermistor is reached at 63.2% of the ambient temperature change under zero power condition
Material Constant B	$2800 \pm 10\%$ $B = T_1 T_2 / (T_2 - T_1) \times \ln(R_1 / R_2)$	R1, R2 is zero-power resistance at T <sub>1</sub> , T <sub>2</sub> T <sub>1</sub> = 298.15 K(25 C) T <sub>2</sub> = 323.15 K(50 C)

Item	Specification	Test Conditions & Methods															
Max.Steady State Current	visible mechanical damage $\Delta R_N / R_N \leq 20\%$ ( $\Delta R =  R_N - R_N' $ )	25 C $\pm$ 2 C Ambient temp. Range 7.0A Testing Current															
Temperature change	No visible mechanical damage. $\Delta R_N / R_N \leq 20\%$ ( $\Delta R =  R_N - R_N' $ )	5 Cycles <table border="1"> <thead> <tr> <th>Step</th> <th>Temperature( C )</th> <th>Time(min)</th> </tr> </thead> <tbody> <tr> <td>1</td> <td><math>T_U \pm 2</math></td> <td>30<math>\pm</math>3</td> </tr> <tr> <td>2</td> <td>Room</td> <td>5<math>\pm</math>3</td> </tr> <tr> <td>3</td> <td><math>T_L \pm 2</math></td> <td>30<math>\pm</math>3</td> </tr> <tr> <td>4</td> <td>Room</td> <td>5<math>\pm</math>3</td> </tr> </tbody> </table>	Step	Temperature( C )	Time(min)	1	$T_U \pm 2$	30 $\pm$ 3	2	Room	5 $\pm$ 3	3	$T_L \pm 2$	30 $\pm$ 3	4	Room	5 $\pm$ 3
Step	Temperature( C )	Time(min)															
1	$T_U \pm 2$	30 $\pm$ 3															
2	Room	5 $\pm$ 3															
3	$T_L \pm 2$	30 $\pm$ 3															
4	Room	5 $\pm$ 3															
Electrical Cycling Testing	No visible mechanical damage. $\Delta R_N / R_N \leq 20\%$ ( $\Delta R =  R_N - R_N' $ )	Ambient temp. Range:25 C $\pm$ 2 C. Cycles: 1,000times On / Off: 1m / 5m Test Current:7 A After recovering 4~5h under 25 $\pm$ 2 C , the rated zero power resistance value RN' shall be measured.															
LoadLife ( Endurance ) Testing	No visible mechanical damage. $\Delta R_N / R_N \leq 20\%$ ( $\Delta R =  R_N - R_N' $ )	Ambient temp. Range:25 C $\pm$ 2 C ; 7A/ 1,000 $\pm$ 24h After recovering 4~5 h under 25 $\pm$ 2 C , the rated zero power resistance value RN' shall be measured															
Steady state	No visible damage, insulation resistance meets the requirements $\Delta R_N / R_N \leq 20\%$ ( $\Delta R =  R_N - R_N' $ )	40 $\pm$ 2 C , 93%RH,1000H															

## CHARACTERISTIC CURVES

Graph of Voltage vs. Current

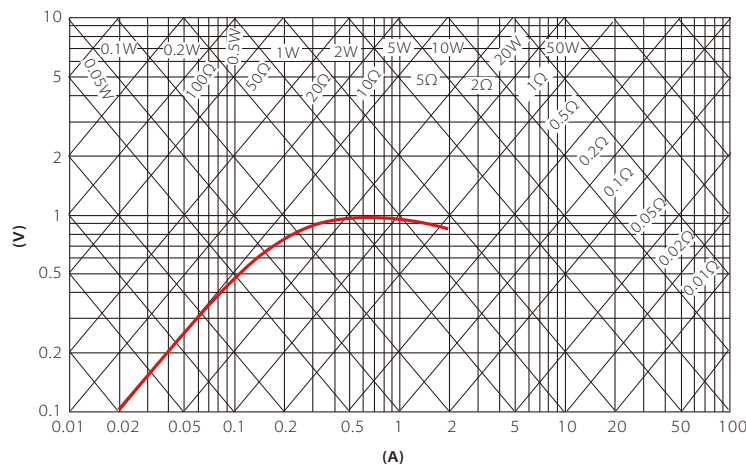

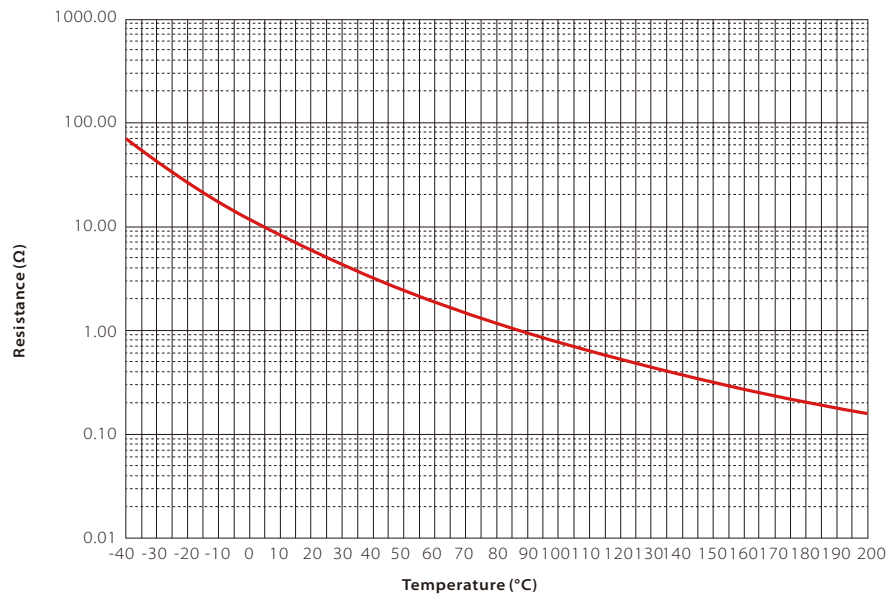
**Graph of Resistance vs. Temperature**

**R-T chart**

Temp °C	Resistance Ω			Temp °C	Resistance Ω		
	lower limiting value	Central value	upper-limit value		lower limiting value	Central value	upper-limit value
-40.0	42.21	68.55	106.89	-21.0	18.69	27.73	39.50
-39.0	40.31	65.13	101.02	-20.0	17.97	26.54	37.64
-38.0	38.50	61.90	95.53	-19.0	17.28	25.41	35.88
-37.0	36.79	58.85	90.37	-18.0	16.62	24.34	34.22
-36.0	35.18	55.98	85.54	-17.0	15.99	23.32	32.64
-35.0	33.64	53.28	81.00	-16.0	15.39	22.35	31.15
-34.0	32.18	50.72	76.73	-15.0	14.82	21.43	29.74
-33.0	30.80	48.31	72.73	-14.0	14.27	20.55	28.40
-32.0	29.49	46.03	68.96	-13.0	13.75	19.71	27.13
-31.0	28.25	43.87	65.42	-12.0	13.25	18.92	25.93
-30.0	27.06	41.83	62.08	-11.0	12.77	18.16	24.79
-29.0	25.94	39.91	58.94	-10.0	12.31	17.44	23.71
-28.0	24.87	38.08	55.99	-9.0	11.87	16.75	22.68
-27.0	23.85	36.36	53.20	-8.0	11.45	16.09	21.70
-26.0	22.88	34.72	50.57	-7.0	11.05	15.46	20.78
-25.0	21.96	33.17	48.10	-6.0	10.67	14.87	19.90
-24.0	21.08	31.70	45.76	-5.0	10.30	14.30	19.06
-23.0	20.25	30.31	43.55	-4.0	9.94	13.75	18.26
-22.0	19.45	28.99	41.47	-3.0	9.61	13.23	17.50

Temp °C	Resistance Ω			Temp °C	Resistance Ω		
	lower limiting value	Central value	upper-limit value		lower limiting value	Central value	upper-limit value
-2.0	9.28	12.74	16.78	33.0	3.05	3.91	4.81
-1.0	8.97	12.26	16.10	34.0	2.96	3.80	4.68
0.0	8.67	11.81	15.44	35.0	2.86	3.69	4.56
1.0	8.38	11.38	14.82	36.0	2.77	3.58	4.44
2.0	8.11	10.96	14.23	37.0	2.68	3.48	4.33
3.0	7.84	10.57	13.66	38.0	2.60	3.38	4.21
4.0	7.59	10.19	13.12	39.0	2.52	3.28	4.11
5.0	7.35	9.82	12.61	40.0	2.44	3.19	4.00
6.0	7.11	9.47	12.12	41.0	2.36	3.10	3.90
7.0	6.89	9.14	11.65	42.0	2.29	3.01	3.80
8.0	6.67	8.82	11.21	43.0	2.22	2.93	3.71
9.0	6.46	8.52	10.78	44.0	2.15	2.85	3.62
10.0	6.26	8.22	10.37	45.0	2.09	2.77	3.53
11.0	6.07	7.94	9.98	46.0	2.03	2.70	3.44
12.0	5.88	7.67	9.61	47.0	1.97	2.62	3.36
13.0	5.70	7.41	9.25	48.0	1.91	2.55	3.28
14.0	5.53	7.16	8.91	49.0	1.85	2.48	3.20
15.0	5.36	6.93	8.59	50.0	1.80	2.42	3.12
16.0	5.20	6.70	8.28	51.0	1.75	2.35	3.05
17.0	5.05	6.48	7.98	52.0	1.70	2.29	2.97
18.0	4.90	6.27	7.69	53.0	1.65	2.23	2.90
19.0	4.76	6.06	7.42	54.0	1.60	2.17	2.84
20.0	4.62	5.87	7.16	55.0	1.56	2.12	2.77
21.0	4.49	5.68	6.90	56.0	1.51	2.06	2.71
22.0	4.36	5.50	6.66	57.0	1.47	2.01	2.64
23.0	4.23	5.33	6.43	58.0	1.43	1.96	2.58
24.0	4.12	5.16	6.21	59.0	1.39	1.91	2.53
25.0	4.00	5.00	6.00	60.0	1.35	1.86	2.47
26.0	3.86	4.85	5.83	61.0	1.31	1.82	2.41
27.0	3.73	4.70	5.67	62.0	1.28	1.77	2.36
28.0	3.61	4.55	5.52	63.0	1.24	1.73	2.31
29.0	3.49	4.42	5.36	64.0	1.21	1.69	2.26
30.0	3.37	4.28	5.22	65.0	1.18	1.65	2.21
31.0	3.26	4.15	5.08	66.0	1.15	1.61	2.16
32.0	3.16	4.03	4.94	67.0	1.12	1.57	2.11



Temp °C	Resistance Ω			Temp °C	Resistance Ω		
	lower limiting value	Central value	upper-limit value		lower limiting value	Central value	upper-limit value
68.0	1.09	1.53	2.07	103.0	0.47	0.71	1.04
69.0	1.06	1.49	2.20	104.0	0.46	0.70	1.02
70.0	1.03	1.46	1.98	105.0	0.45	0.69	1.00
71.0	1.01	1.43	1.94	106.0	0.44	0.67	0.99
72.0	0.98	1.39	1.90	107.0	0.43	0.66	0.97
73.0	0.95	1.36	1.86	108.0	0.42	0.65	0.95
74.0	0.93	1.33	1.82	109.0	0.41	0.63	0.94
75.0	0.91	1.30	1.78	110.0	0.40	0.62	0.92
76.0	0.88	1.27	1.75	111.0	0.40	0.61	0.90
77.0	0.86	1.24	1.71	112.0	0.39	0.60	0.89
78.0	0.84	1.21	1.68	113.0	0.38	0.59	0.87
79.0	0.82	1.18	1.64	114.0	0.37	0.58	0.86
80.0	0.80	1.16	1.61	115.0	0.36	0.57	0.85
81.0	0.78	1.13	1.58	116.0	0.36	0.56	0.83
82.0	0.76	1.11	1.55	117.0	0.35	0.55	0.82
83.0	0.74	1.08	1.51	118.0	0.34	0.54	0.80
84.0	0.73	1.06	1.49	119.0	0.34	0.53	0.79
85.0	0.71	1.04	1.46	120.0	0.33	0.52	0.78
86.0	0.69	1.01	1.43	121.0	0.32	0.51	0.77
87.0	0.68	0.99	1.40	122.0	0.32	0.50	0.75
88.0	0.66	0.97	1.37	123.0	0.31	0.49	0.74
89.0	0.64	0.95	1.35	124.0	0.30	0.48	0.73
90.0	0.63	0.93	1.32	125.0	0.30	0.47	0.72
91.0	0.62	0.91	1.30	126.0	0.29	0.46	0.71
92.0	0.60	0.89	1.27	127.0	0.29	0.46	0.70
93.0	0.59	0.87	1.25	128.0	0.28	0.45	0.68
94.0	0.57	0.86	1.23	129.0	0.28	0.44	0.67
95.0	0.56	0.84	1.20	130.0	0.27	0.43	0.66
96.0	0.55	0.82	1.18	131.0	0.27	0.43	0.65
97.0	0.54	0.80	1.16	132.0	0.26	0.42	0.64
98.0	0.52	0.79	1.14	133.0	0.26	0.41	0.63
99.0	0.51	0.77	1.12	134.0	0.25	0.40	0.62
100.0	0.50	0.76	1.10	135.0	0.25	0.40	0.61
101.0	0.49	0.74	1.08	136.0	0.24	0.39	0.61
102.0	0.48	0.73	1.06	137.0	0.24	0.38	0.60

Temp °C	Resistance Ω			Temp °C	Resistance Ω		
	lower limiting value	Central value	upper-limit value		lower limiting value	Central value	upper-limit value
138.0	0.23	0.38	0.59	157.0	0.17	0.28	0.45
139.0	0.23	0.37	0.58	158.0	0.17	0.28	0.44
140.0	0.23	0.37	0.57	159.0	0.16	0.27	0.44
141.0	0.22	0.36	0.56	160.0	0.16	0.27	0.43
142.0	0.22	0.35	0.55	161.0	0.16	0.26	0.42
143.0	0.21	0.35	0.55	162.0	0.15	0.26	0.42
144.0	0.21	0.34	0.54	163.0	0.15	0.26	0.41
145.0	0.21	0.34	0.53	164.0	0.15	0.25	0.41
146.0	0.20	0.33	0.52	165.0	0.15	0.25	0.40
147.0	0.20	0.33	0.52	166.0	0.15	0.25	0.40
148.0	0.20	0.32	0.51	167.0	0.14	0.24	0.39
149.0	0.19	0.32	0.50	168.0	0.14	0.24	0.39
150.0	0.19	0.31	0.49	169.0	0.14	0.23	0.38
151.0	0.19	0.31	0.49	170.0	0.14	0.23	0.38
152.0	0.18	0.30	0.48	171.0	0.13	0.23	0.37
153.0	0.18	0.30	0.47	172.0	0.13	0.22	0.37
154.0	0.18	0.29	0.47	173.0	0.13	0.22	0.36
155.0	0.17	0.29	0.46	174.0	0.13	0.22	0.36
156.0	0.17	0.28	0.45	175.0	0.13	0.22	0.35

## PACKAGE INFORMATION

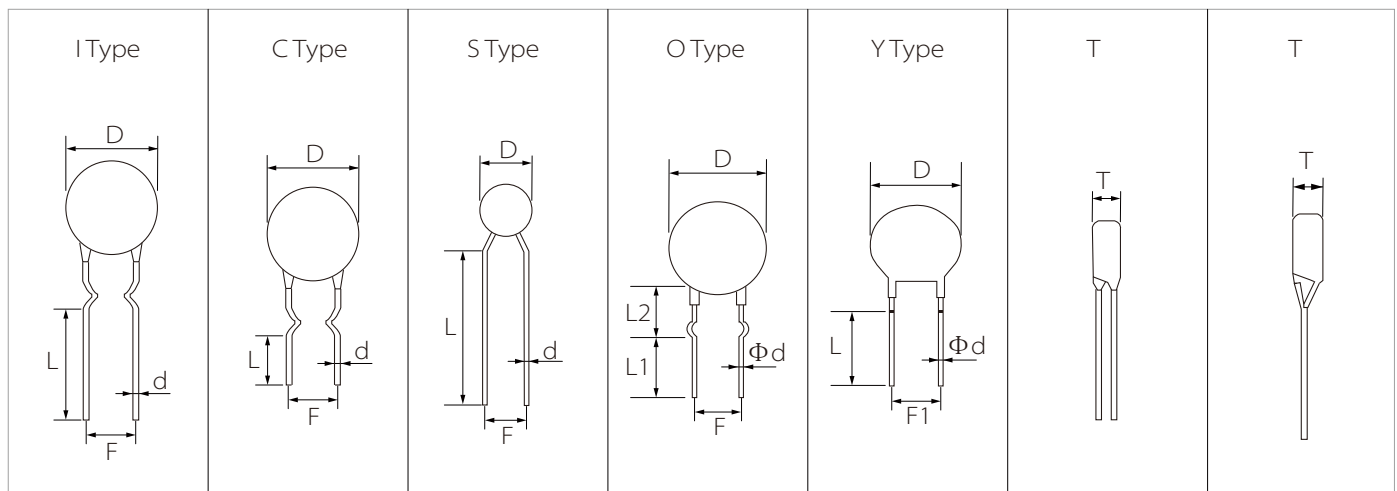

Part No	Dmax	Tmax	$\Phi d \pm 0.05$		F1 $\pm 1$	F2 $\pm 1.5$	Straight Lead Wire	Curved Lead wire	
			CP	Cu				L $\pm 1$	L1 $\pm 0.5$
NTC□D-5	7	5	0.55	0.6	5	3	2.8-20	2.8-20	7 or 4
NTC□D-7	9	5	0.55	0.6	5	3	2.8-20	2.8-20	7 or 4
NTC□D-9	11	5.5	0.75/0.55	0.8/0.6	7.5/5	5/3	2.8-20	2.8-20	7 or 4
NTC□D-11	13	5.5	0.75	0.8	7.5/5	5/3	2.8-20	2.8-20	7 or 4
NTC□D-13	15.5	6	0.75	0.8	7.5	5	2.8-20	2.8-20	7 or 4
NTC□D-15	17.5	6	0.75	0.8	10/7.5	5	2.8-20	2.8-20	7 or 4
NTC□D-20	22.5	7	1.0	1.0	10/7.5	7	2.8-20	2.8-20	7 or 4

## NORMAL PRODUCT PACKAGING

Dimension	Bag	Inside the box	carton
NTC□D-5	1000 pcs	3000 pcs	18000 pcs
NTC□D-7	1000 pcs	3000 pcs	18000 pcs
NTC□D-9	500 pcs	2000 pcs	12000 pcs
NTC□D-11	500 pcs	1500 pcs	9000 pcs
NTC□D-13	250 pcs	1000 pcs	6000 pcs
NTC□D-15	250 pcs	1000 pcs	6000 pcs
NTC□D-20	100 pcs	400 pcs	2400 pcs

## CUT THE FEET PRODUCT PACKAGING

Dimension	Bag	Inside the box	Carton
NTC□D-5	1000 pcs	8000 pcs	48000 pcs
NTC□D-7	1000 pcs	5000 pcs	30000 pcs
NTC□D-9	1000 pcs	4000 pcs	24000 pcs
NTC□D-11	1000 pcs	3000 pcs	18000 pcs
NTC□D-13	500 pcs	2000 pcs	12000 pcs
NTC□D-15	500 pcs	1000 pcs	6000 pcs

**Headquarters**

No.3387 Shendu Road Pujiang  
I&E Park  
Minhang Shanghai China  
201000

**Hotline**

400-021-5756

**Web**

<https://www.semiware.com>

**Sales Center**

Tel: 86-21-3463-7458  
Email: [sales18@semiware.com](mailto:sales18@semiware.com)

**Customer Service**

Tel: 86-21-5484-1001  
Email: [sales17@semiware.com](mailto:sales17@semiware.com)

**Technical Support**

Tel: 86-21-3463-7654  
Email: [fae01@semiware.com](mailto:fae01@semiware.com)

**Complaint & Suggestions**

Tel: 86-21-3463-7172  
Ext: 8868  
Email: [cs03@semiware.com](mailto:cs03@semiware.com)

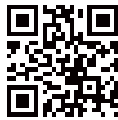
**By QR Code**

Website



Wechat

To find your local partner within Semiware's global network: [www.semiware.com](http://www.semiware.com)

© 2022 Semiware Semiconductor Inc.

The content of this document has been carefully checked and understood. However, neither Semiware nor its subsidiaries assume any liability whatsoever for any errors or inaccuracies of this document and the consequences thereof. Published specifications are subject to change without notice. Product suitability for any area of application must ultimately be determined by the customer. In all cases, products must never be operated outside their published specifications. Semiware does not guarantee the availability of all published products. This disclaimer shall be governed by substantive Chinese law and resulting disputes shall be settled by the courts at the place of business of Semiware. Latest publications and a complete disclaimer can be downloaded from the Semiware website. All trademarks recognized.