

## FEATURES

|  $V_{DS}=100V, R_{DS(ON)} \leq 235m\Omega @ V_{GS}=10V, I_D=1.6A$

| For Low power DC to DC converter application

| For Load switch application

| Surface Mount device



## APPLICATION

| Case: SOT-23

| Case Material: Molded Plastic. UL flammability

| Classification Rating: 94V-0

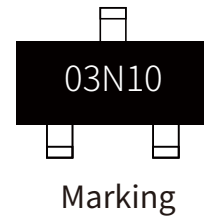

## APPROVALS

**RoHS** Compliance with 2011/65/EU

**HF** Compliance with IEC61249-2-21:2003

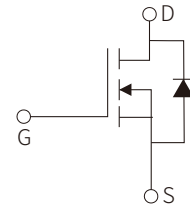

Schematic Symbol

## ABSOLUTE MAXIMUM RATINGS( $T_a=25^\circ C$ )

Parameter	Symbol	Value	Unit
Drain-Source Voltage	$V_{DS}$	100	V
Drain Current-Continuous	$I_D$	1.6	A
Drain Current-Continuous	$I_D$	1.3	A
Pulsed Drain Voltage	$I_{DM}$	7	A
Gate-Source Voltage	$V_{GS}$	$\pm 16$	V
Total Power Dissipation	$P_D$	1.3	W
Total Power Dissipation	$P_D$	0.8	W
Linear Derating Factor		0.01	W/°C
Thermal Resistance.Junction- to-Ambient (Note.1)	$R_{thJA}$	100	°C/W
		99	°C/W
Junction Temperature	$T_J$	150	°C
Storage temperature	$T_{STG}$	-55 to 150	°C

Note.1: Surface mounted on 1 in square Cu board

## ELECTRICAL CHARACTERISTICS(T<sub>a</sub>=25°C)

Parameter	Symbol	Test Conditions	Min.	Typ.	Max.	Unit
Drain-source Breakdown Voltage	BV <sub>DSS</sub>	V <sub>GS</sub> =0V, I <sub>D</sub> =250μA	100			V
Zero Gate Voltage Drain Current	I <sub>DSS</sub>	V <sub>DS</sub> =100V, V <sub>GS</sub> =0V			20	μA
		V <sub>DS</sub> =100V, V <sub>GS</sub> =0V, T <sub>J</sub> =125°C			250	μA
Gate-Body Leakage	I <sub>GSS</sub>	V <sub>GS</sub> =±16V, V <sub>DS</sub> =0V			±100	nA
Gate Threshold Voltage	V <sub>GS(th)</sub>	V <sub>DS</sub> =V <sub>GS</sub> , I <sub>D</sub> =250μA	1		3	V
Static Drain-Source On-Resistance(Note1)	R <sub>DS(on)</sub>	V <sub>GS</sub> =4.5V, I <sub>D</sub> =1.3A		190	235	mΩ
		V <sub>GS</sub> =10V, I <sub>D</sub> =1.6A		178	220	
Forward Transconductance	g <sub>FS</sub>	V <sub>DS</sub> =50V, I <sub>D</sub> =1.6A	5.7			S
Gate resistance	R <sub>g</sub>			1.3		Ω
Input Capacitance	C <sub>iss</sub>	V <sub>DS</sub> =25V, V <sub>GS</sub> =0V, f=1.0MHz		290		pF
Output Capacitance	C <sub>oss</sub>			27		
Reverse Transfer Capacitance	C <sub>rss</sub>			13		
Turn-On Delay Time	t <sub>d(on)</sub>	V <sub>GS</sub> =4.5V, R <sub>G</sub> =6.8Ω V <sub>DS</sub> =50V, I <sub>D</sub> =1A		2.2		ns
Turn-On Rise Time	t <sub>r</sub>			2.1		
Turn-Off Delay Time	t <sub>d(off)</sub>			9		
Turn-Off Fall Time	t <sub>f</sub>			3.6		
Diode forward voltage	V <sub>SD</sub>	I <sub>S</sub> =1.1A, V <sub>GS</sub> =0V, T <sub>J</sub> =25°C			1.3	V
Total Gate Charge	Q <sub>g</sub>	V <sub>GS</sub> =4.5V, V <sub>DS</sub> =50V, I <sub>D</sub> =1.6A		2.5		nC
Gate Source Charge	Q <sub>gs</sub>			0.5		
Gate Drain Charge	Q <sub>gd</sub>			1.2		
Diode forward current(Body Diode)	I <sub>S</sub>				1.1	A
Pulsed Source Current(Body Diode)	I <sub>SM</sub>	(Note.2)			7	A
Reverse Recovery Time	t <sub>rr</sub>	I <sub>F</sub> =1.1A, V <sub>R</sub> =50V dI/dt=100A/μs, T <sub>J</sub> =25°C, (Note.1)		20	30	ns
Reverse Recovery Charge	Q <sub>rr</sub>				13	20

Note.1: Pulse test ; Pulse width ≤400μs, Duty cycle ≤ 2%

Note.2: Repetitive rating; pulse width limited by max. junction temperature.

# PARAMETER CHARACTERISTIC CURVE

**Fig 1: Typical Output Characteristics**

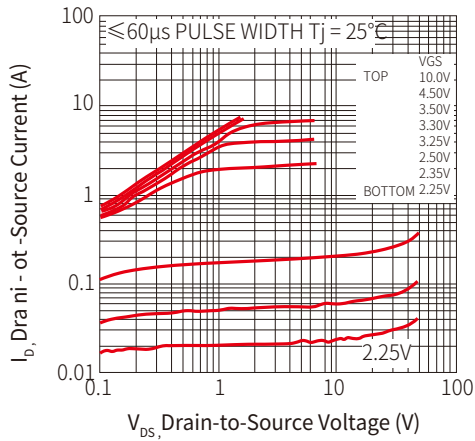

**Figure 2: Typical Output Characteristics**

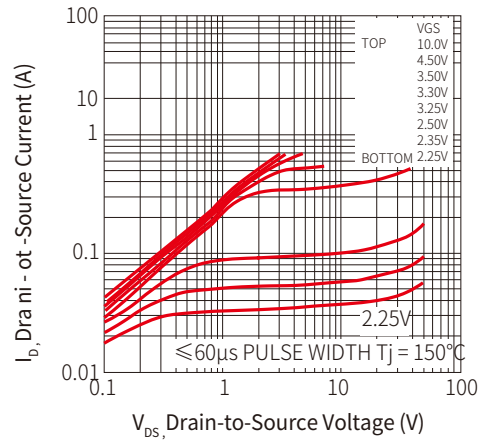

**Figure 3: Typical Transfer Characteristics**

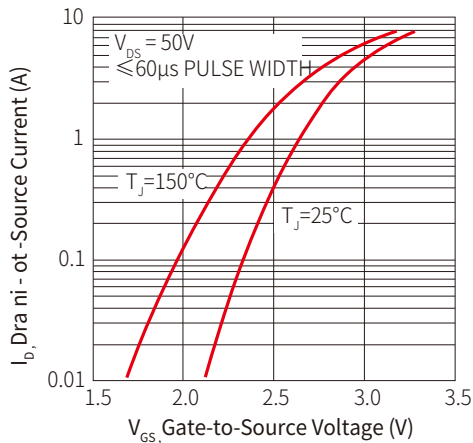

**Figure 4: Normalized On-Resistance Vs. Temperature**

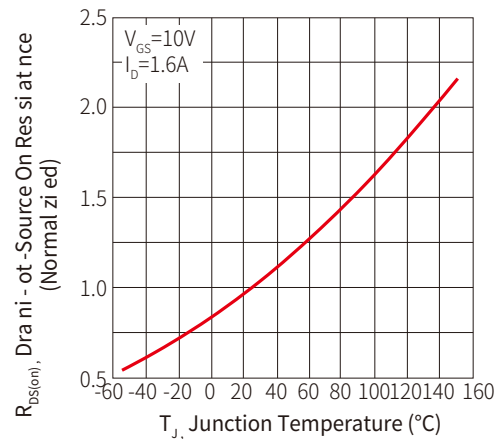

**Figure 5: Typical Capacitance Vs. Drain-to-Source Voltage**

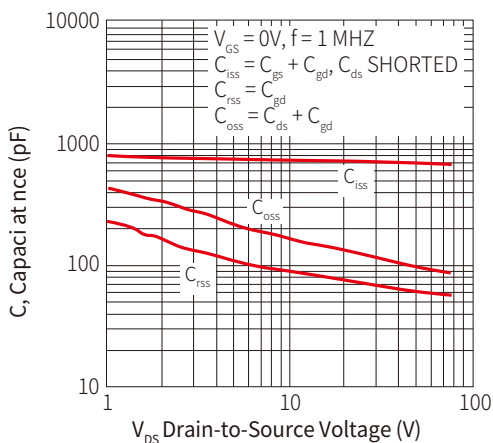

**Figure 6: Typical Gate Charge Vs. Gate-to-Source Voltage**

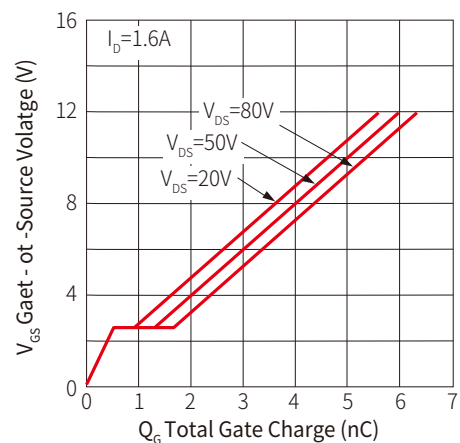

**Figure 7: Typical Source-Drain Diode Forward Voltage**

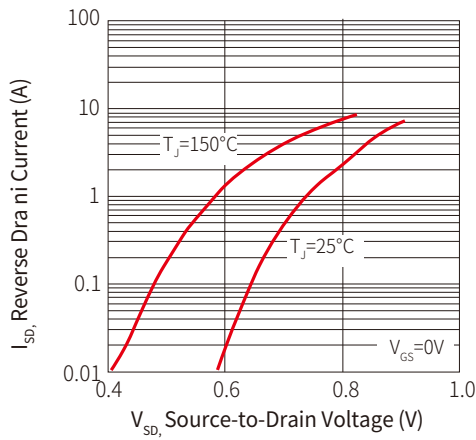

**Figure 8: Maximum Safe Operating Area**

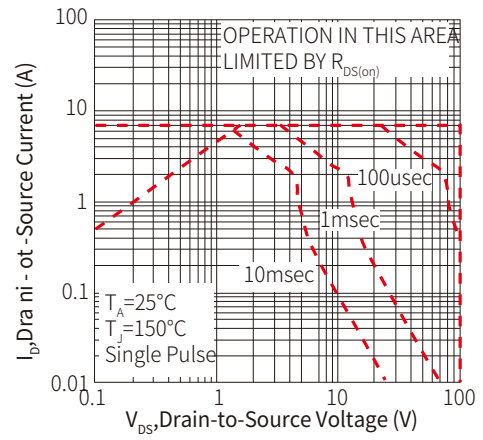

**Figure 9: Maximum Drain Current Vs. Ambient Temperature**

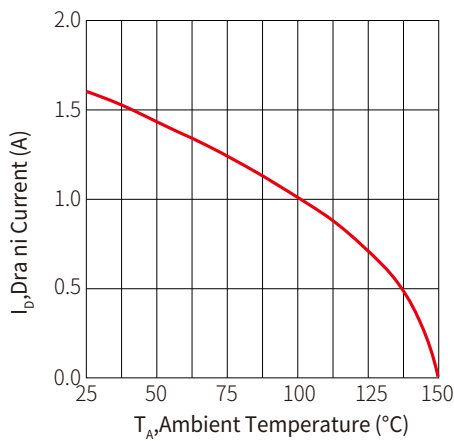

**Figure 10: Typical On-Resistance Vs. Gate Voltage**

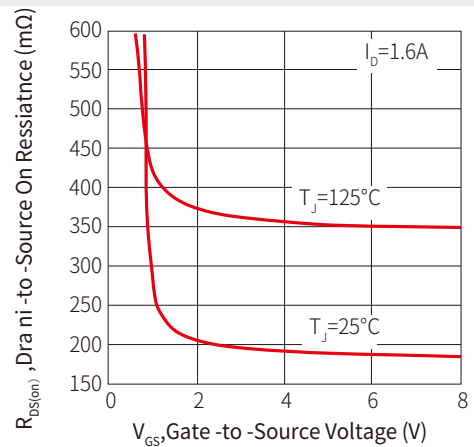

**Figure 11: Typical On-Resistance Vs. Drain Current**

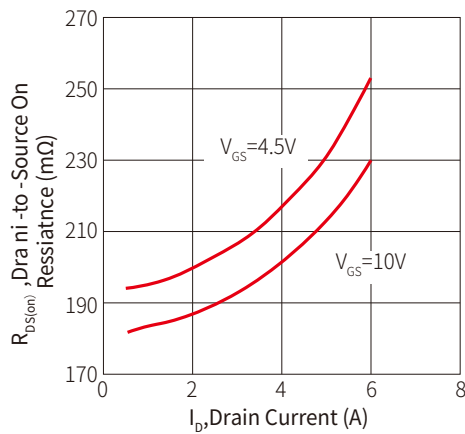

**Figure 12: Typical Threshold Voltage Vs. Junction Temperature**

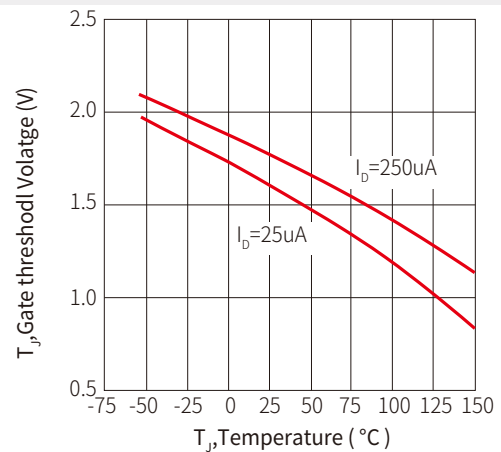

Figure 13: Typical Power Vs. Time

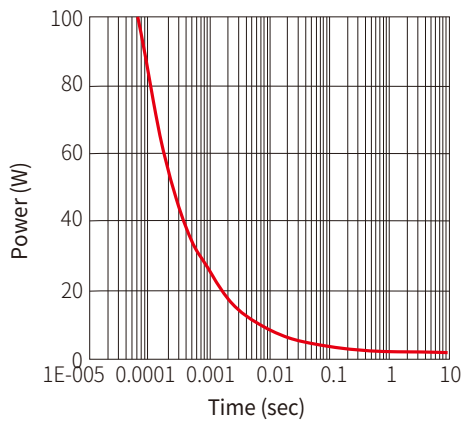

Figure 14: Typical Effective Transient Thermal Impedance, Junction-to-Ambient

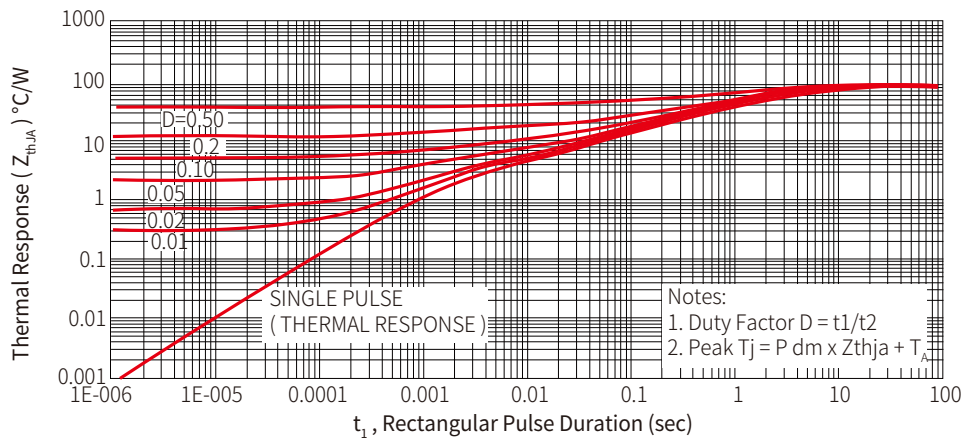
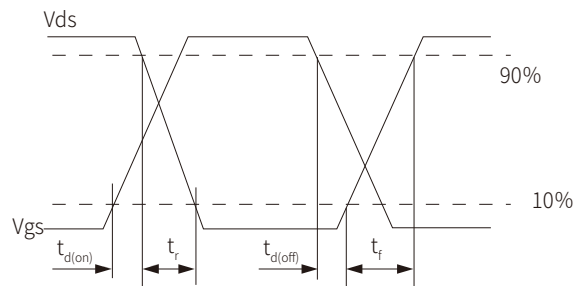
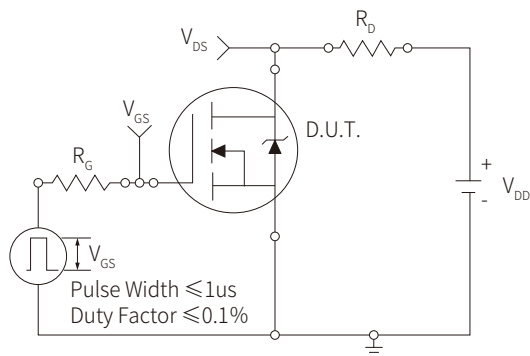
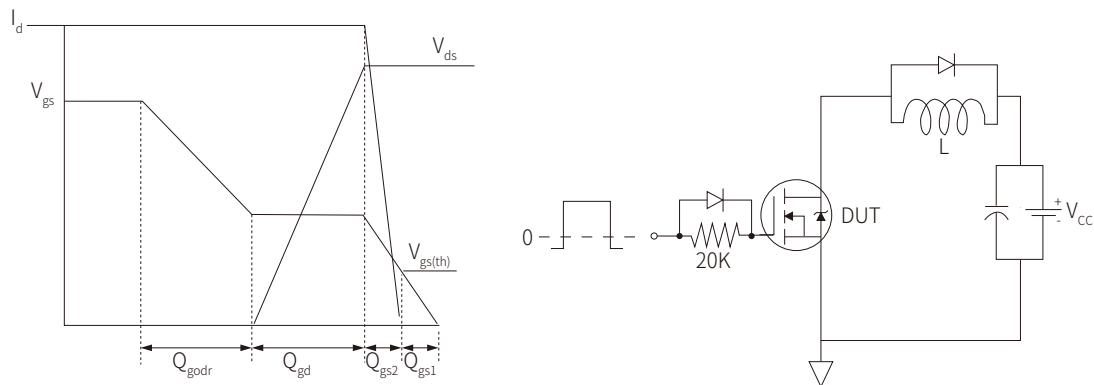

Figure 15: Switching Time Test Circuit & Waveforms



**Figure 16: Basic Gate Charge Waveform & Test Circuit**

## SOLDERING PARAMETERS

Reflow Condition		Lead-free assembly
Pre Heat	Temperature Max ( $T_{s(min)}$ )	150°C
	Temperature Max ( $T_{s(max)}$ )	200°C
	Time (min to max) ( $t_s$ )	60 – 180 secs
Average ramp up rate (Liquidus Temp ( $T_L$ ) to peak)		3°C/second max
$T_{s(max)}$ to $T_L$ - Ramp-up Rate		3°C/second max
Reflow	Temperature ( $T_L$ ) (Liquidus)	217°C
	Time (min to max) ( $t_L$ )	60 – 150 seconds
Peak Temperature ( $T_p$ )		260°C
Time within 5°C of actual peak Temperature ( $t_p$ )		20 – 40 seconds
Ramp-down Rate		6°C/second max
Time 25°C to peak Temperature ( $T_p$ )		8 minutes max.
Do not exceed		260°C

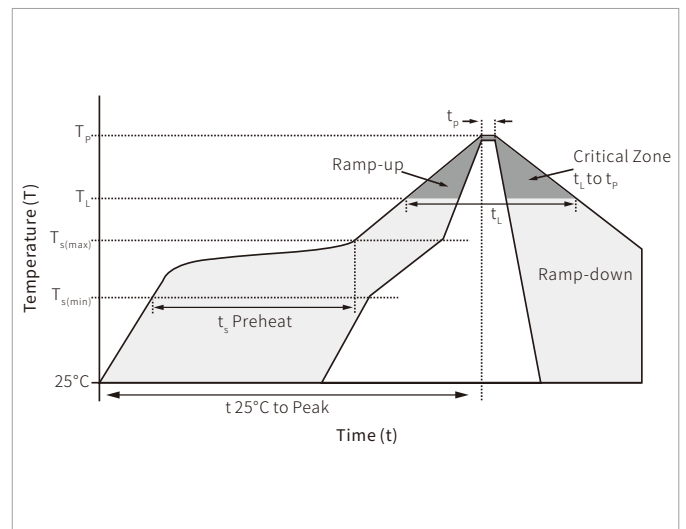

## SOT-23 PACKAGE INFORMATION

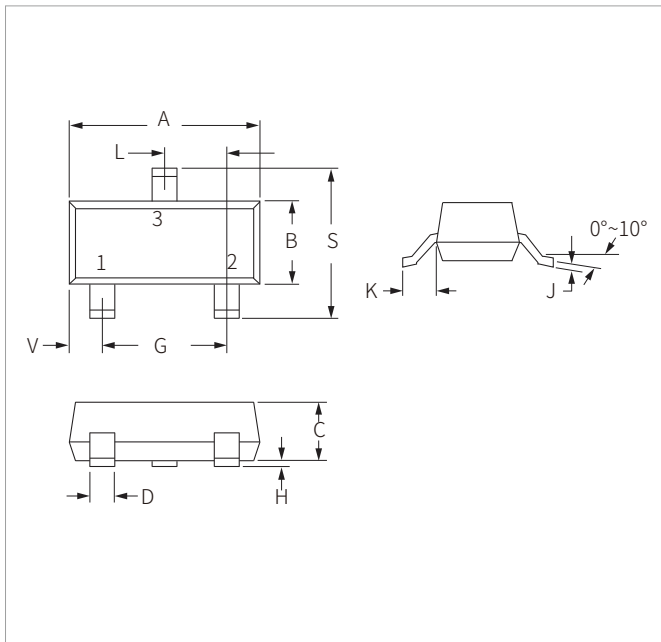

Ref.	Millimeters		Inches	
	Min.	Max.	Min.	Max.
A	2.80	3.05	0.110	0.120
B	1.20	1.40	0.047	0.055
C	0.90	1.15	0.035	0.045
D	0.37	0.50	0.015	0.020
G	1.75	2.05	0.069	0.081
H	0.01	0.100	0.001	0.004
J	0.085	0.180	0.003	0.007
K	0.35	0.69	0.014	0.029
L	0.89	1.02	0.035	0.040
S	2.10	2.65	0.083	0.104
V	0.45	0.60	0.018	0.024

## RECOMMENDED PAD LAYOUT DIMENSIONS

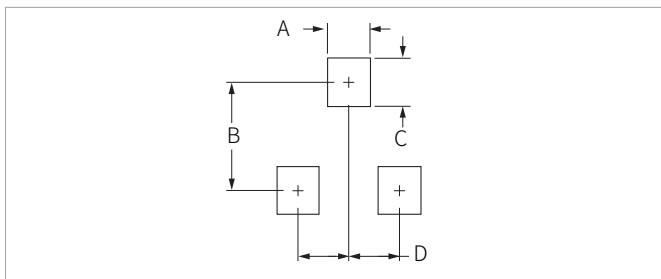

Ref.	Millimeters		Inches	
	Min.	Max.	Min.	Max.
A	0.71	0.97	0.028	0.038
B	1.88	2.13	0.074	0.084
C	0.71	0.97	0.028	0.038
D	0.81	1.07	0.032	0.042

## ORDERING INFORMATION

Part Number	Component Package	QTY/Reel	Reel Size
SNM0100S	SOT-23	3000PCS	7"

**Headquarters**

No.3387 Shendu Road  
Pujiang I&E Park  
Minhang Shanghai China  
201000

**Hotline**

400-021-5756

**Web**

<https://www.semiware.com>

**Sales Center**

Tel: 86-21-3463-7458  
Email: [sales18@semiware.com](mailto:sales18@semiware.com)

**Customer Service**

Tel: 86-21-5484-1001  
Email: [sales17@semiware.com](mailto:sales17@semiware.com)

**Technical Support**

Tel: 86-21-3463-7654  
Email: [fae01@semiware.com](mailto:fae01@semiware.com)

**Complaint & Suggestions**

Tel: 86-21-3463-7172  
Ext: 8868  
Email: [cs03@semiware.com](mailto:cs03@semiware.com)

**By QR Code**

Website



Wechat

To find your local partner within Semiware' s global website: [www.semiware.com](http://www.semiware.com)

© 2022 Semiware Semiconductor Inc.

The content of this document has been carefully checked and understood. However, neither Semiware nor its subsidiaries assume any liability whatsoever for any errors or inaccuracies of this document and the consequences thereof. Published specifications are subject to change without notice. Product suitability for any area of application must ultimately be determined by the customer. In all cases, products must never be operated outside their published specifications. Semiware does not guarantee the availability of all published products. This disclaimer shall be governed by substantive Chinese law and resulting disputes shall be settled by the courts at the place of business of Semiware. Latest publications and a complete disclaimer can be downloaded from the Semiware website. All trademarks recognized.