

FEATURES

| $R_{DS(ON)}$ Typ = 4.5m Ω @ $V_{GS} = 10V$

| $R_{DS(ON)}$ Typ = 5.7m Ω @ $V_{GS} = 4.5V$

| Advanced Trench Technology

| Excellent $R_{DS(ON)}$ and Low Gate Charge

| 100% UIS TESTED!

| 100% ΔV_{ds} TESTED!

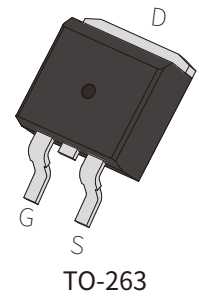

APPLICATION

| Load Switch

| PWM Application

| Power Management

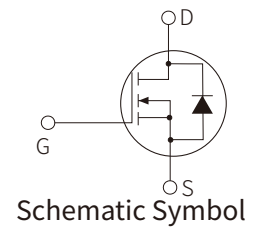

APPROVALS

RoHS | Compliance with 2011/65/EU

HF | Compliance with IEC61249-2-21:2003

ABSOLUTE MAXIMUM RATINGS

Parameter	Symbol	Value	Unit	
Drain-to-Source Voltage	V_{DS}	100	V	
Pulsed Drain Current ⁽¹⁾	I_{DM}	440	A	
Continuous Drain Current	I_D	$T_c = 25^\circ C$	110	A
		$T_c = 100^\circ C$	66	A
Power Dissipation $T_c = 25^\circ C$	P_D	125	W	
Gate-to-Source Voltage	V_{GS}	± 20	V	
Single Pulsed Avalanche Energy ⁽²⁾	E_{AS}	182	mJ	
Junction & Storage Temperature Range	T_J, T_{STG}	-55 to 150	$^\circ C$	
Thermal Resistance, Junction to Case	$R_{\theta JC}$	1	$^\circ C/W$	

ELECTRICAL CHARACTERISTICS (T_A=25°C)

Parameter	Symbol	Test Conditions	Min.	Typ.	Max.	Unit
Off Characteristics						
Drain-Source Breakdown Voltage	BV _{DSS}	V _{GS} =0V, I _{DS} =250μA	100			V
Gate Leakage Current	I _{GSS}	V _{GS} =±20V, V _{DS} =0V			±100	nA
Drain Leakage Current	I _{DSS}	V _{DS} =100V, V _{GS} =0V			1.0	μA
On Characteristics						
Gate Threshold Voltage	V _{GS(th)}	V _{DS} =V _{GS} , I _D =250μA	1.2	1.7	2.3	V
Static Drain-Source ON-Resistance	R _{DS(on)}	V _{GS} =10V, I _D =30A		4.5	5.8	mΩ
		V _{GS} =4.5V, I _D =20A		5.7	7.4	mΩ
Dynamic Characteristics						
Input capacitance	C _{iss}	V _{GS} =0V, V _{DS} =50V, f = 1MHz		2819		pF
Output capacitance	C _{oss}			790		pF
Reverse transfer capacitance	C _{rss}			16		pF
Total Gate Charge	Q _g	V _{DS} =50V, V _{GS} =0 to 10V I _D =20A		45		nC
Gate-Source Charge	Q _{gs}			7		nC
Gate Drain("Miller") Charge	Q _{gd}			10		nC
Switching Characteristics						
Turn-on Delay Time	t _{d(on)}	V _{DD} =50V, V _{GS} =10V R _{GEN} = 3Ω, I _D =20A		12		nS
Turn-on Rise Time	t _r			18		nS
Turn-Off Delay Time	t _{d(off)}			49		nS
Turn-Off Fall Time	t _f			38		nS
Drain-Source Diode Characteristics and Max Ratings						
Drain to Source Diode Forward Voltage	V _{SD}	I _S =30A, V _{GS} =0V			1.2	V
Body Diode Reverse Recovery Time	t _{rr}	I _F =20A di/dt = 100A/us		50		nS
Body Diode Reverse Recovery Charge	Q _{rr}			41		nC
Maximum Continuous Drain to Source Diode Forward Current	I _S				110	A
Maximum Pulsed Drain to Source Diode Forward Current	I _{SM}				440	A

Notes:

1. Repetitive Rating: Pulse Width Limited by Maximum Junction Temperature
2. E_{AS} condition: Starting T_J=25°C, V_{DD}=50V, V_G=10V, R_G=25ohm, L=0.5mH, I_{AS}=27A
3. Pulse Test: Pulse Width ≤ 300μs, Duty Cycle ≤ 0.5%

PARAMETER CHARACTERISTIC CURVE

Fig 1: Output Characteristics

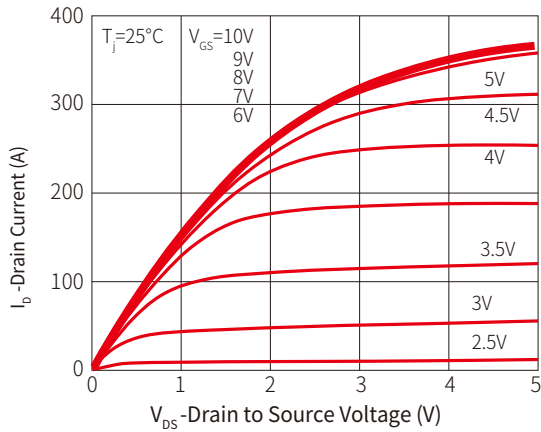

Figure 2: Typical Transfer Characteristics

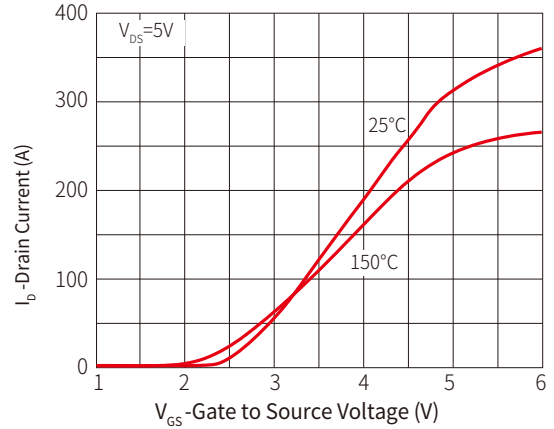

Figure 3: Capacitance Characteristics

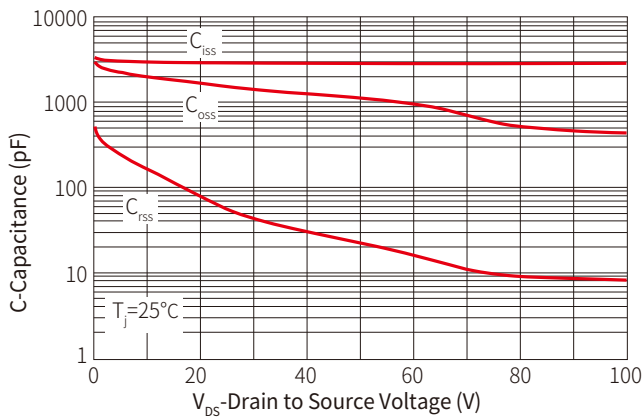

Figure 4: Gate Charge

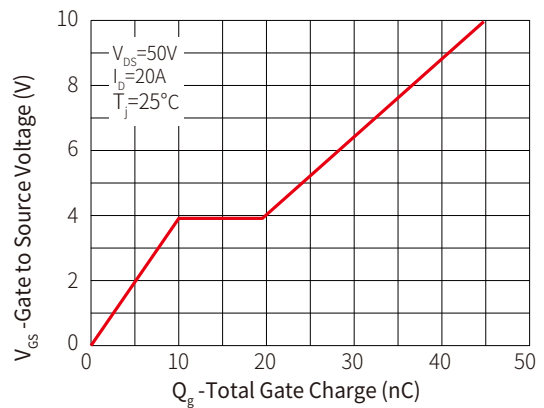

Figure 5: On-Resistance vs Gate to Source Voltage

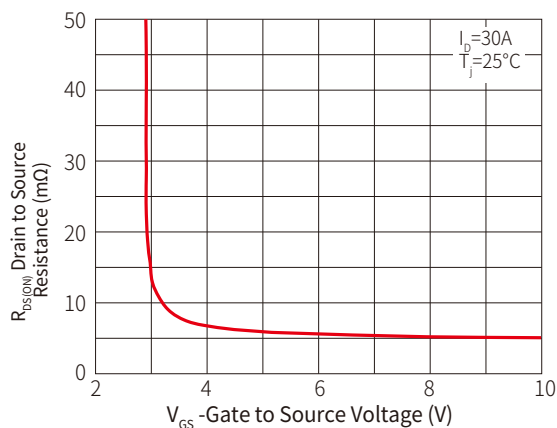

Figure 6: Normalized On-Resistance

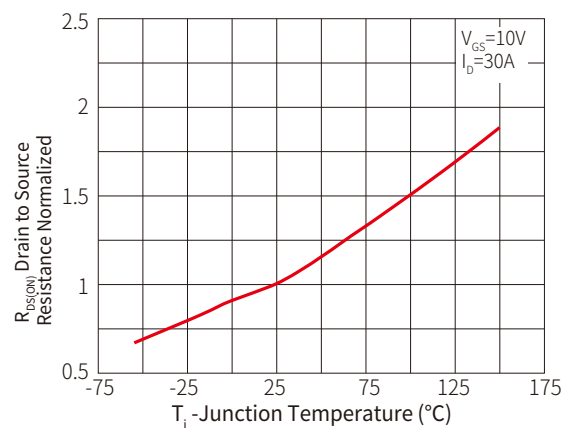

Figure 7: $R_{DS(on)}$ VS Drain Current

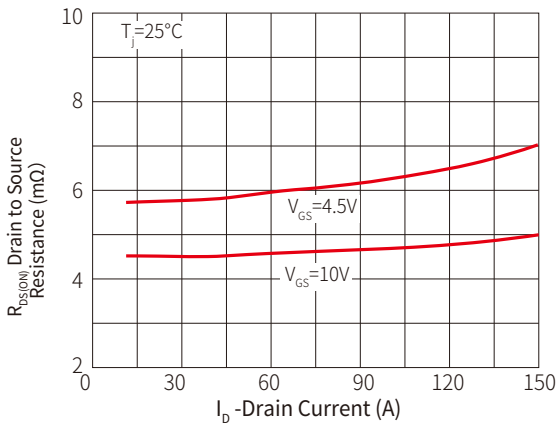

Figure 8: Forward characteristics of reverse diode

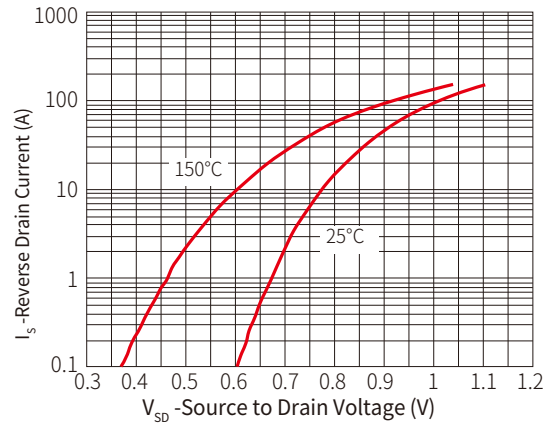

Figure 9: Normalized breakdown voltage

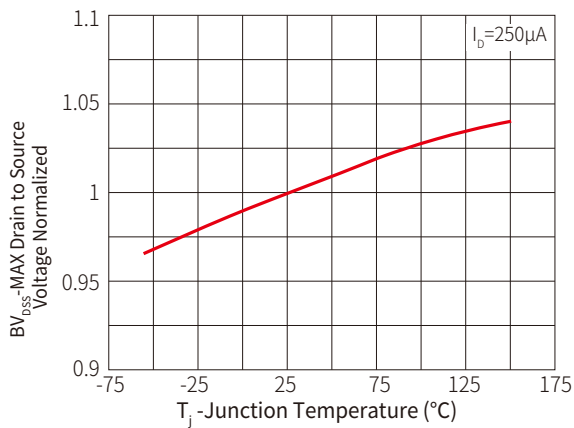

Figure 10: Normalized Threshold voltage

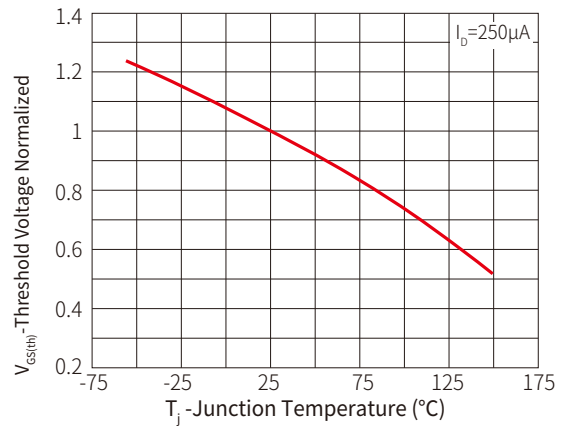

Figure 11: Current dissipation

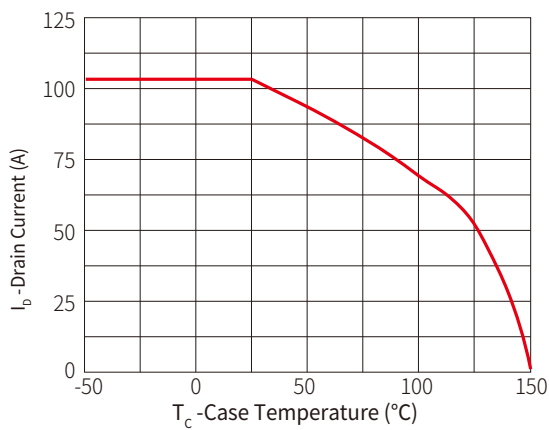

Figure 12: Power dissipation

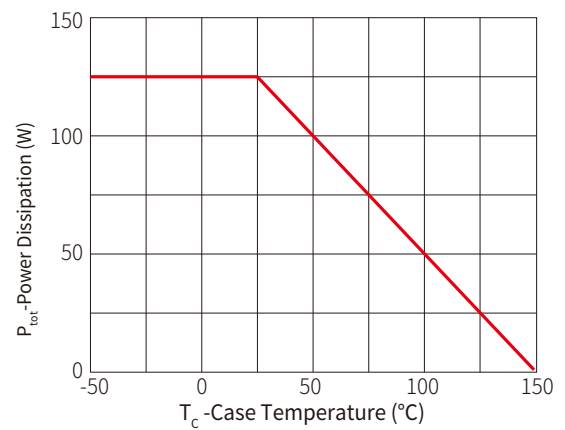
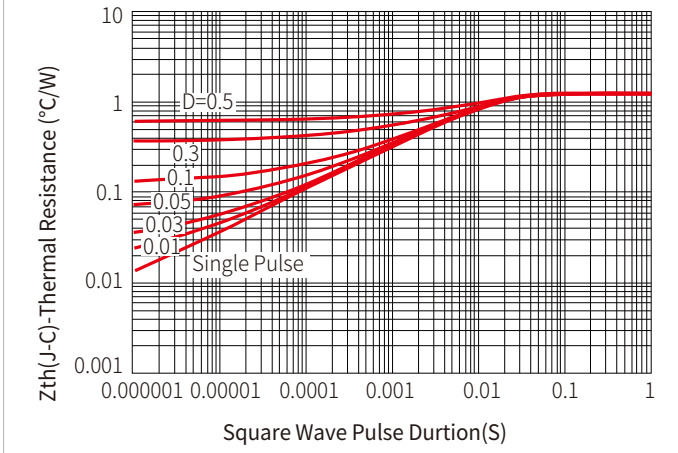
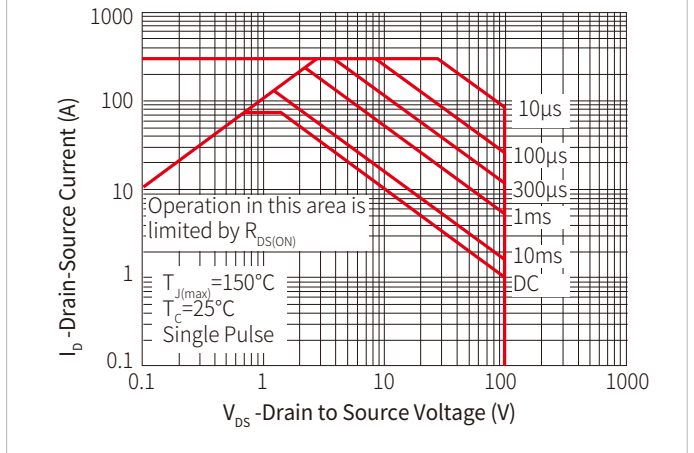
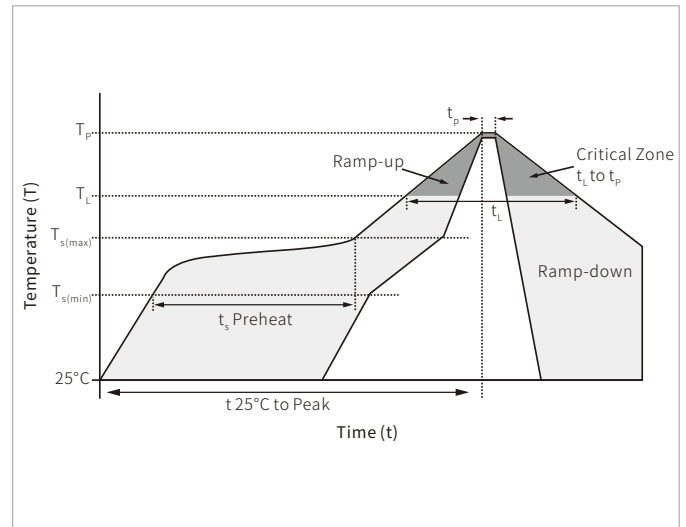

Figure 13: Maximum Transient Thermal Impedance

Figure 14: Safe Operation Area

SOLDERING PARAMETERS

Reflow Condition		Lead-free assembly
Pre Heat	Temperature Max ($T_{s(min)}$)	150°C
	Temperature Max ($T_{s(max)}$)	200°C
	Time (min to max) (t_s)	60 – 180 secs
Average ramp up rate (Liquidus Temp (T_L) to peak)		3°C/second max
$T_{s(max)}$ to T_L - Ramp-up Rate		3°C/second max
Reflow	Temperature (T_L) (Liquidus)	217°C
	Time (min to max) (t_L)	60 – 150 seconds
Peak Temperature (T_p)		260°C
Time within 5°C of actual peak Temperature (t_p)		20 – 40 seconds
Ramp-down Rate		6°C/second max
Time 25°C to peak Temperature (T_p)		8 minutes max.
Do not exceed		260°C

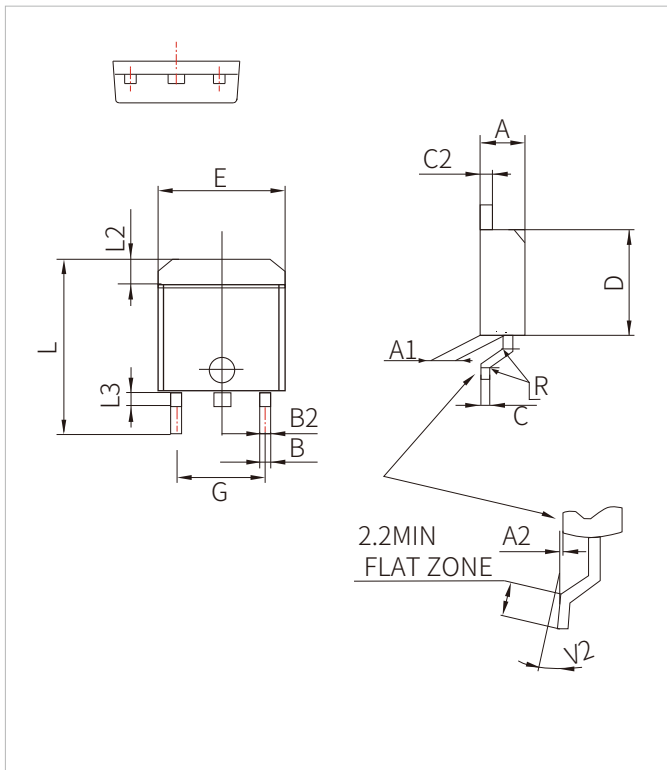

TO-263 PACKAGE MECHANICAL DATA



Ref.	Dimensions					
	Millimeters			Inches		
	Min.	Typ.	Max.	Min.	Typ.	Max.
A	4.30		4.60	0.169		0.181
A1	2.49		2.69	0.098		0.106
A2	0.03		0.23	0.001		0.009
B	0.70		0.93	0.027		0.037
B2	1.25	1.40		0.048	0.055	
C	0.45		0.60	0.017		0.024
C2	1.21		1.36	0.047		0.054
D	8.95		9.35	0.352		0.368
E	9.80		10.28	0.386		0.405
G	4.88		5.28	0.192		0.208
L	14.80		15.85	0.583		0.624
L2	1.27		1.40	0.050		0.055
L3	1.40		1.75	0.055		0.069
R		0.40			0.016	
V2	0°		8°	0°		8°

ORDERING INFORMATION

Part Number	Component Package	Marking	QTY/Reel	Reel Size
SNM110N10E	TO-263	 110N10 XXXX	800PCS	13"

Headquarters

No.3387 Shendu Road
Pujiang I&E Park
Minhang Shanghai China
201000

Hotline

400-021-5756

Web

<https://www.semiware.com>

Sales Center

Tel: 86-21-3463-7458
Email: sales18@semiware.com

Customer Service

Tel: 86-21-5484-1001
Email: sales17@semiware.com

Technical Support

Tel: 86-21-3463-7654
Email: fae01@semiware.com

Complaint & Suggestions

Tel: 86-21-3463-7172
Ext: 8868
Email: cs03@semiware.com

By QR Code

Website



Wechat

To find your local partner within Semiware' s global website: www.semiware.com

© 2022 Semiware Semiconductor Inc.

The content of this document has been carefully checked and understood. However, neither Semiware nor its subsidiaries assume any liability whatsoever for any errors or inaccuracies of this document and the consequences thereof. Published specifications are subject to change without notice. Product suitability for any area of application must ultimately be determined by the customer. In all cases, products must never be operated outside their published specifications. Semiware does not guarantee the availability of all published products. This disclaimer shall be governed by substantive Chinese law and resulting disputes shall be settled by the courts at the place of business of Semiware. Latest publications and a complete disclaimer can be downloaded from the Semiware website. All trademarks recognized.