

FEATURES

- | Energy Efficient

- | Low Threshold Voltage

- | High-speed Switching

- | DC/DC Converter

- | Meet AEC-Q101 Requirements

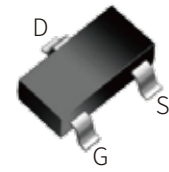

SOT-23

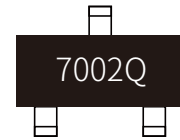

Marking

MECHANICAL DATA

- | SOT-23 Small Outline Plastic Package

- | Epoxy UL: 94V-0

- | Mounting Position: Any

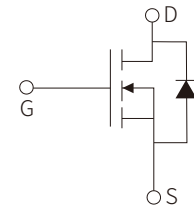

Schematic Symbol

APPROVALS

| | |
|-------------|------------------------------------|
| RoHS | Compliance with 2011/65/EU |
| HF | Compliance with IEC61249-2-21:2003 |

ABSOLUTE MAXIMUM RATINGS($T_a=25^{\circ}\text{C}$)

| Parameter | Symbol | Value | Unit |
|---|-----------------|------------|-----------------------------|
| Drain-Source Voltage | V_{DS} | 60 | V |
| Continuous Drain Current | I_D | 0.4 | A |
| Gate Source Voltage | V_{GS} | ± 20 | V |
| Power Dissipation | P_D | 225 | mW |
| Thermal Resistance From Junction to Ambient | $R_{\theta JA}$ | 556 | $^{\circ}\text{C}/\text{W}$ |
| Junction and Storage Temperature Range | T_J, T_{STG} | -55 to 150 | $^{\circ}\text{C}$ |

ELECTRICAL CHARACTERISTICS (T_A=25°C)

| Parameter | Symbol | Test Conditions | Min. | Typ. | Max. | Unit |
|--|----------------------|---|------|------|------|------|
| Static Characteristics | | | | | | |
| Drain-source Breakdown Voltage | V _{(BR)DSS} | V _{GS} =0V, I _{DS} =250μA | 60 | | | V |
| Gate Threshold Voltage | V _{GS(th)} | V _{DS} =V _{GS} , I _D =250μA | 1.0 | 1.5 | 2.0 | V |
| Drain Cut-Off Current | I _{DSS} | V _{DS} =60V, V _{GS} =0V | | | 1 | μA |
| Gate Leakage Current | I _{GSS} | V _{GS} =±20V, V _{DS} =0V | | | ±100 | nA |
| Drain Source ON Resistance | R _{DS(on)} | V _{GS} =10V, I _D =0.2A | | 690 | 900 | mΩ |
| | | V _{GS} =4.5V, I _D =0.1A | | 800 | 1060 | mΩ |
| Dynamic Characteristics | | | | | | |
| Total Gate Charge | Q _g | V _{DS} =30V, V _{GS} =10V, I _D =300mA | | 1.6 | | nC |
| Gate-Source Charge | Q _{gs} | | | 0.47 | | nC |
| Gate-Drain Charge | Q _{gd} | | | 0.25 | | nC |
| Input capacitance | C _{iss} | V _{GS} =0V, V _{DS} =30V, f=1.0MHz | | 27.5 | | pF |
| Output capacitance | C _{oss} | | | 2.75 | | pF |
| Reverse transfer capacitance | C _{rss} | | | 1.9 | | pF |
| Turn-on Delay Time | t _{d(on)} | V _{DD} =30V, V _{GS} =10V I _D =300mA, R _{GEN} =5Ω | | 3.3 | | ns |
| Turn-on Rise Time | t _r | | | 19 | | ns |
| Turn-Off Delay Time | t _{d(off)} | | | 9.6 | | ns |
| Turn-Off Fall Time | t _f | | | 49 | | ns |
| Drain Source Body Diode Characteristics | | | | | | |
| Source Drain Diode Forward Voltage | V _{SD} | I _S =115A, V _{GS} =0V | 0.55 | | 1.2 | V |
| Maximum Continuous Drain to Source Diode Forward Current | I _S | | | | 0.4 | A |

PARAMETER CHARACTERISTIC CURVE

Figure 1: Output Characteristics

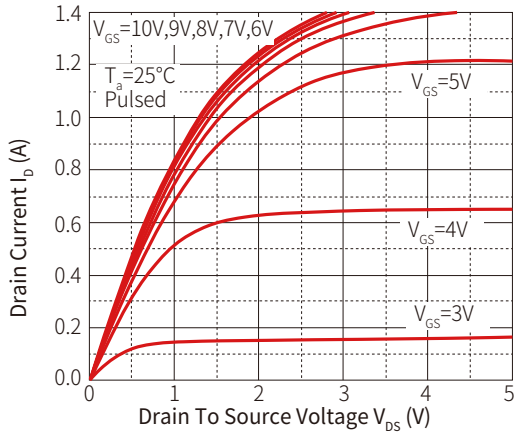

Figure 2: Typical Characteristics

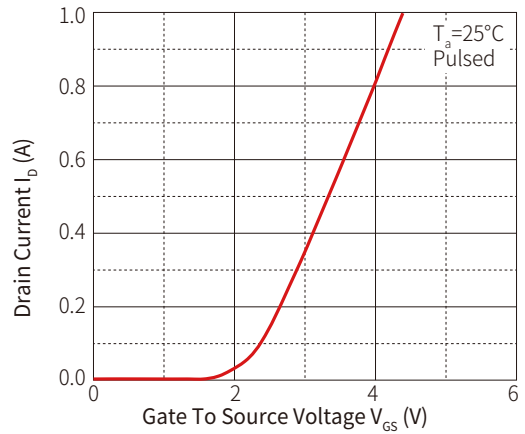

Figure 3: $R_{DS(ON)}$ vs I_D

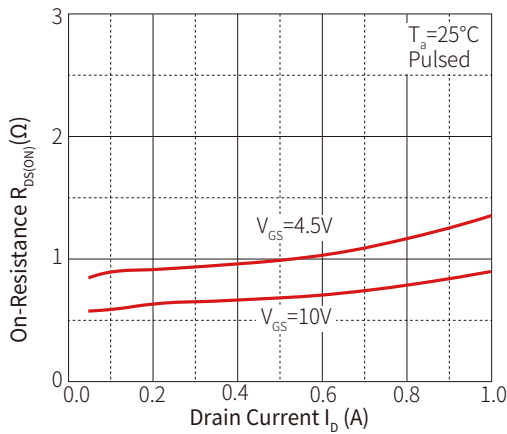

Figure 4: $R_{DS(ON)}$ vs V_{GS}

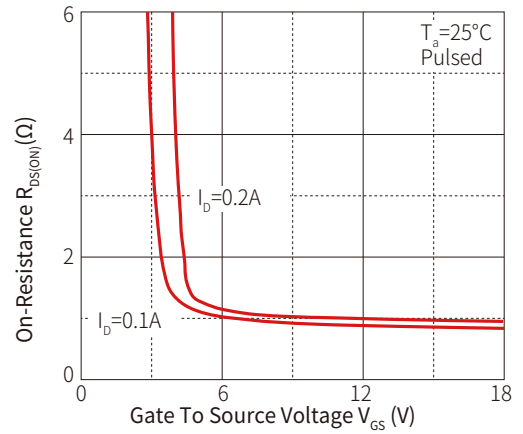

Figure 5: Drain-Source On Resistance

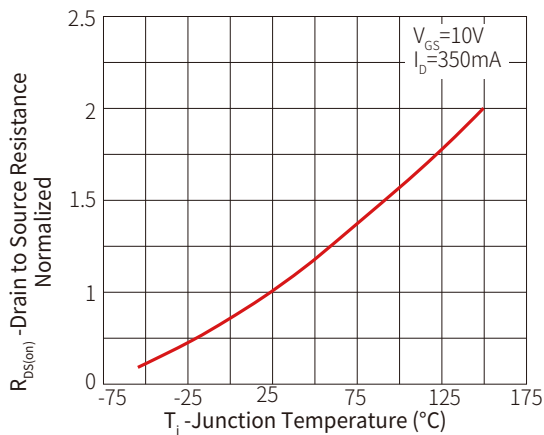

Figure 6: Drain Current

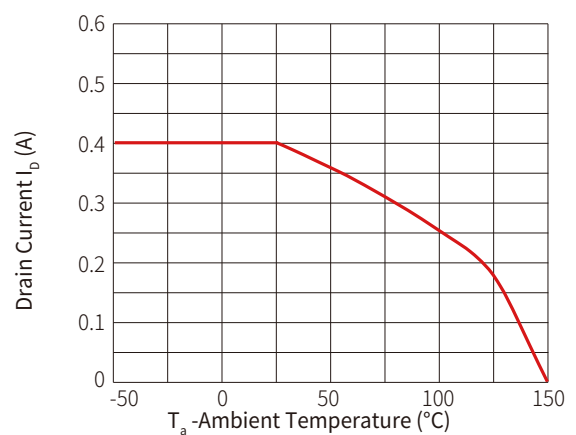

Figure 7: I_s — V_{DS}

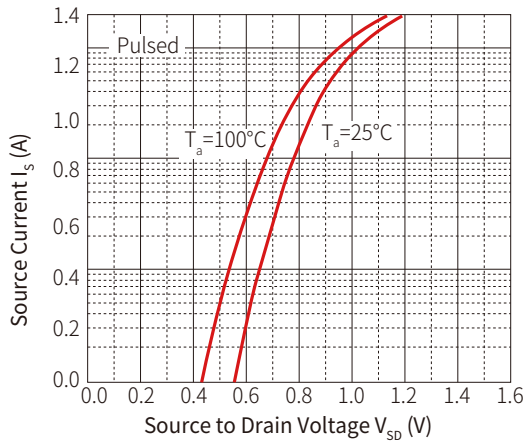

Figure 8: Threshold Voltage

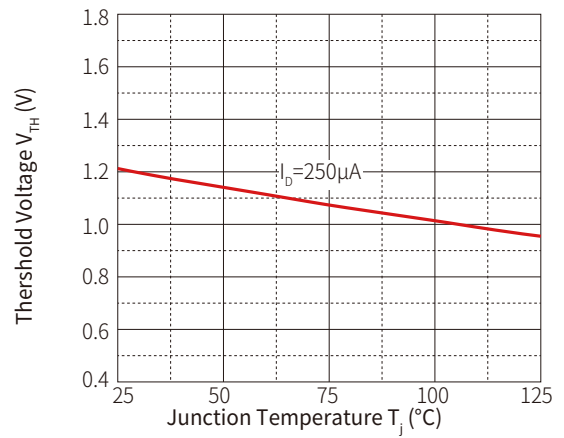

Figure 9: Capacitance

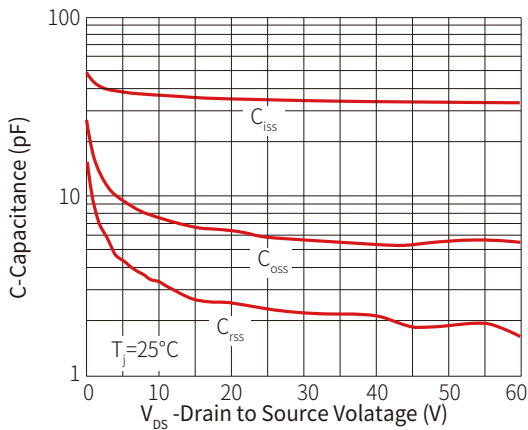

Figure 10: Gate Charge Characteristics

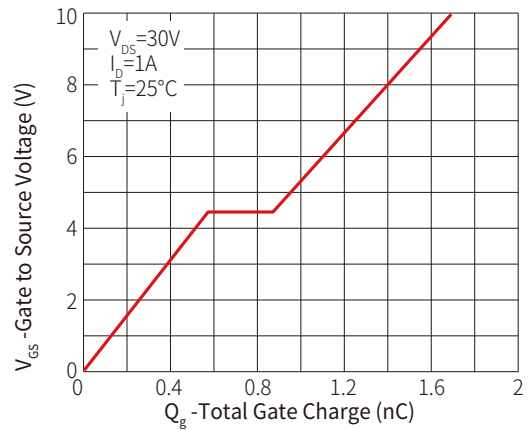

Figure 11: Normalized Breakdown Voltage vs. Junction Temperature

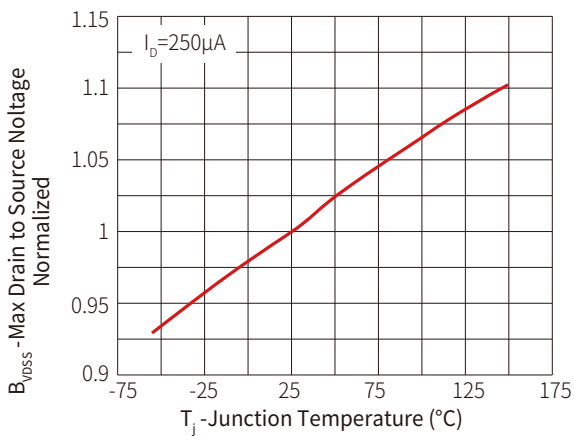

Figure 11: Power Dissipation

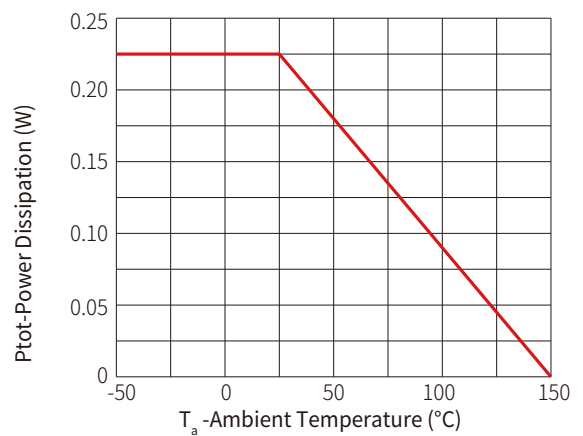
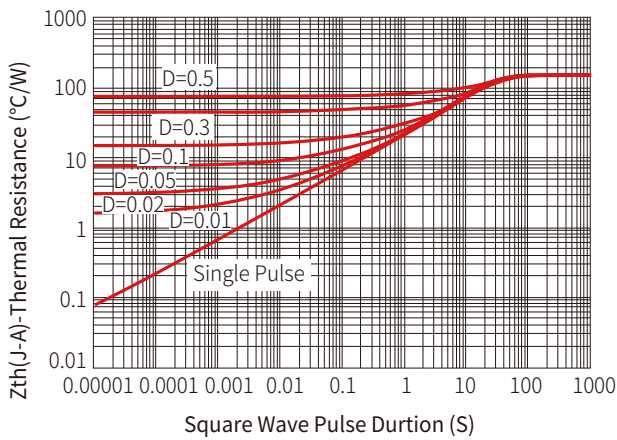
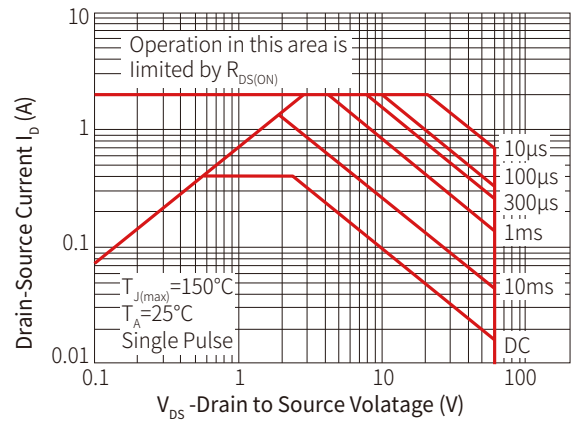
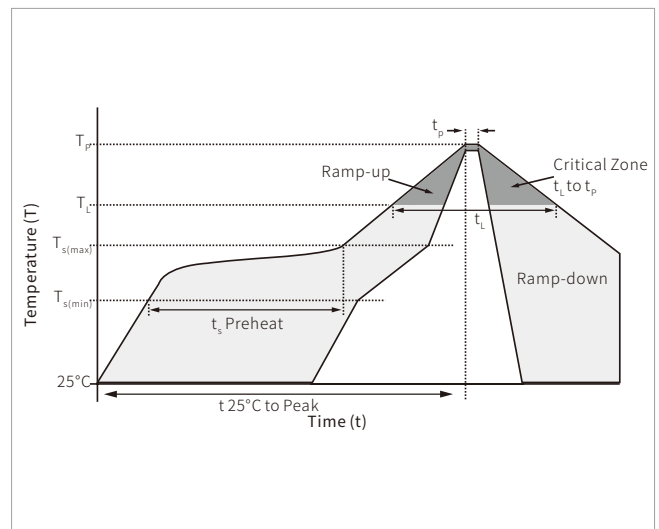

Figure 7: Maximum Effective Transient Thermal Impedance, Junction-to-Ambient

Figure 8: Maximum Safe Operating Area

SOLDERING PARAMETERS

| Reflow Condition | | Lead-free assembly |
|--|----------------------------------|--------------------|
| Pre Heat | Temperature Max ($T_{s(min)}$) | 150°C |
| | Temperature Max ($T_{s(max)}$) | 200°C |
| | Time (min to max) (t_s) | 60 – 180 secs |
| Average ramp up rate (Liquidus Temp (T_L) to peak) | | 3°C/second max |
| $T_{s(max)}$ to T_L - Ramp-up Rate | | 3°C/second max |
| Reflow | Temperature (T_L) (Liquidus) | 217°C |
| | Time (min to max) (t_l) | 60 – 150 seconds |
| Peak Temperature (T_p) | | 260°C |
| Time within 5°C of actual peak Temperature (t_p) | | 20 – 40 seconds |
| Ramp-down Rate | | 6°C/second max |
| Time 25°C to peak Temperature (T_p) | | 8 minutes max. |
| Do not exceed | | 260°C |

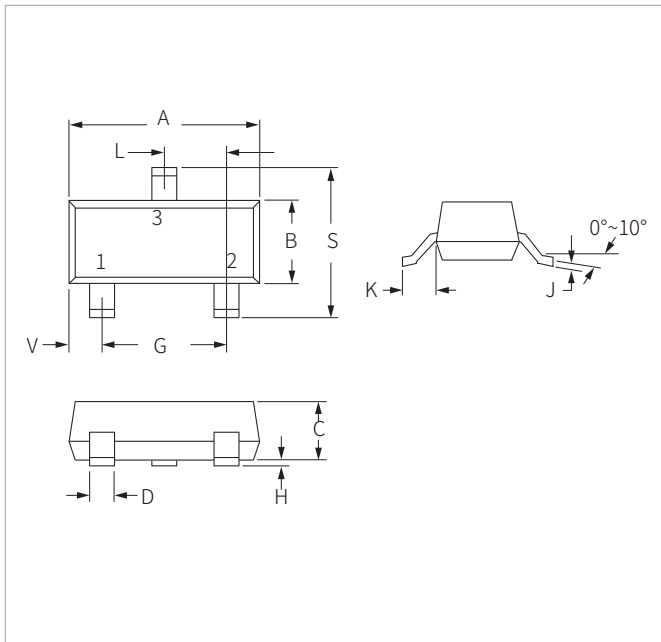

SOT-23 PACKAGE INFORMATION



| Ref. | Millimeters | | Inches | |
|------|-------------|-------|--------|-------|
| | Min. | Max. | Min. | Max. |
| A | 2.80 | 3.05 | 0.110 | 0.120 |
| B | 1.20 | 1.60 | 0.047 | 0.063 |
| C | 0.90 | 1.15 | 0.035 | 0.045 |
| D | 0.37 | 0.50 | 0.015 | 0.020 |
| G | 1.75 | 2.05 | 0.069 | 0.081 |
| H | 0.01 | 0.100 | 0.001 | 0.004 |
| J | 0.085 | 0.180 | 0.003 | 0.007 |
| K | 0.35 | 0.69 | 0.014 | 0.029 |
| L | 0.89 | 1.02 | 0.035 | 0.040 |
| S | 2.10 | 2.65 | 0.083 | 0.104 |
| V | 0.45 | 0.60 | 0.018 | 0.024 |

RECOMMENDED PAD LAYOUT DIMENSIONS

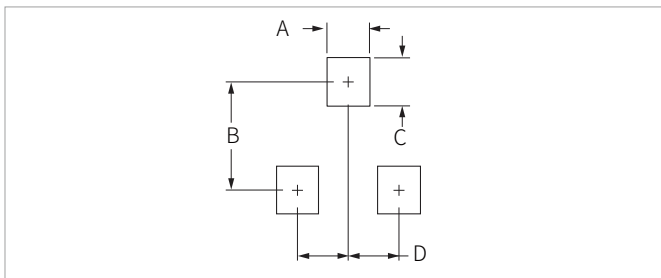

| Ref. | Millimeters | | Inches | |
|------|-------------|------|--------|-------|
| | Min | Max | Min | Max |
| A | 0.71 | 0.97 | 0.028 | 0.038 |
| B | 1.88 | 2.13 | 0.074 | 0.084 |
| C | 0.71 | 0.97 | 0.028 | 0.038 |
| D | 0.81 | 1.07 | 0.032 | 0.042 |

ORDERING INFORMATION

| Part Number | Component Package | QTY/Reel | Reel Size |
|-------------|-------------------|----------|-----------|
| SNM2N7002SQ | SOT-23 | 3000PCS | 7" |

Headquarters

No.3387 Shendu Road
Pujiang I&E Park
Minhang Shanghai China
201000

Hotline

400-021-5756

Web

<https://www.semiware.com>

Sales Center

Tel: 86-21-3463-7458
Email: sales18@semiware.com

Customer Service

Tel: 86-21-5484-1001
Email: sales17@semiware.com

Technical Support

Tel: 86-21-3463-7654
Email: fae01@semiware.com

Complaint & Suggestions

Tel: 86-21-3463-7172
Ext: 8868
Email: cs03@semiware.com

By QR Code

Website



Wechat

To find your local partner within Semiware' s global website: www.semiware.com

© 2022 Semiware Semiconductor Inc.

The content of this document has been carefully checked and understood. However, neither Semiware nor its subsidiaries assume any liability whatsoever for any errors or inaccuracies of this document and the consequences thereof. Published specifications are subject to change without notice. Product suitability for any area of application must ultimately be determined by the customer. In all cases, products must never be operated outside their published specifications. Semiware does not guarantee the availability of all published products. This disclaimer shall be governed by substantive Chinese law and resulting disputes shall be settled by the courts at the place of business of Semiware. Latest publications and a complete disclaimer can be downloaded from the Semiware website. All trademarks recognized.