

FEATURES

| $V_{DS}=20V, R_{DS(ON)} \leq 21m\Omega @ V_{GS}=4.5V, I_D=6.3A$

| Fast switching

| Ultra Low On-Resistance

| Surface Mount device

APPLICATION

| Case: SOT-23

| Case Material: Molded Plastic. UL flammability

| Classification Rating: 94V-0

APPROVALS

RoHS | Compliance with 2011/65/EU

HF | Compliance with IEC61249-2-21:2003

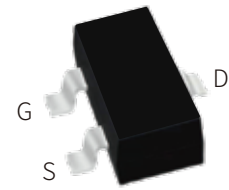

SOT-23

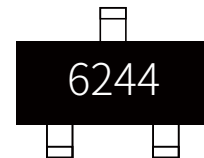

Marking

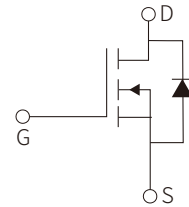

Schematic Symbol

ABSOLUTE MAXIMUM RATINGS($T_a=25^\circ\text{C}$)

Parameter	Symbol	Value	Unit
Drain-Source Voltage	V_{DS}	20	V
Drain Current-Continuous	I_D	6.3	A
Drain Current-Continuous	I_D	5.1	A
Pulsed Drain Voltage	I_{DM}	32	A
Gate-Source Voltage	V_{GS}	± 12	V
Total Power Dissipation	P_D	1.3	W
Total Power Dissipation	P_D	0.8	W
Linear Derating Factor		0.01	W/°C
Thermal resistance from Junction to ambient	$R_{\theta JA}$	100	°C/W
Storage temperature	T_{STG}	-55 to 150	°C

ELECTRICAL CHARACTERISTICS(T_a=25°C)

Parameter	Symbol	Test Conditions	Min.	Typ.	Max.	Unit
Drain-source Breakdown Voltage	BV _{DSS}	V _{GS} =0V, I _D =250μA	20			V
Zero Gate Voltage Drain Current	I _{DSS}	V _{DS} =16V, V _{GS} =0V			1	μA
		V _{DS} =16V, V _{GS} =0V, T _j =125°C			150	μA
Gate-Body Leakage	I _{GSS}	V _{GS} =±12V, V _{DS} =0V			±100	nA
Gate Threshold Voltage (Note1)	V _{GS(th)}	V _{DS} =V _{GS} , I _D =10μA	0.5	0.9	1.1	V
Static Drain-Source On-Resistance(Note1)	R _{DS(on)}	V _{GS} =4.5V, I _D =6.3A		16	21	mΩ
		V _{GS} =2.5V, I _D =5.1A		22	27	
Forward Transconductance(Note1)	g _{FS}	V _{DS} =10V, I _D =6.3A	17			S
Gate resistance	R _g			1.7		Ω
Input Capacitance	C _{iss}	V _{DS} =16V, V _{GS} =0V, f=1.0MHz		700		pF
Output Capacitance	C _{oss}			140		
Reverse Transfer Capacitance	C _{rss}			98		
Turn-On Delay Time	t _{d(on)}	V _{GS} =4.5V, R _G =6.8Ω V _{DD} =10V, I _D =1A		4.9		ns
Turn-On Rise Time	t _r			7.5		
Turn-Off Delay Time	t _{d(off)}			19		
Turn-Off Fall Time	t _f			12		
Diode forward voltage (note 1)	V _{SD}	I _S =6.3A, V _{GS} =0V, T _j =25°C			1.2	V
Total Gate Charge	Q _g	V _{GS} =4.5V, V _{DS} =10V, I _D =6.3A		8.9		nC
Gate Source Charge	Q _{gs}			0.68		
Gate Drain Charge	Q _{gd}			4.4		
Diode forward current(Body Diode)	I _S	integral reverse p-n junction diode			1.3	A
Pulsed Source Current(Body Diode)	I _{SM}				32	A
Reverse Recovery Time	t _{rr}	I _F =1.3A, V _R =15V dI/dt=100A/us, T _j =25°C		12	18	ns
Reverse Recovery Charge	Q _{rr}			5.1	7.7	nC

Note:1. Pulse test ; Pulse width ≤400μs, Duty cycle ≤ 2%

PARAMETER CHARACTERISTIC CURVE

Fig 1: Typical Output Characteristics

Figure 2: Typical Output Characteristics

Figure 3: Typical Transfer Characteristics

Figure 4: Normalized On-Resistance Vs. Temperature

Figure 5: Typical Capacitance Vs. Drain-to-Source Voltage

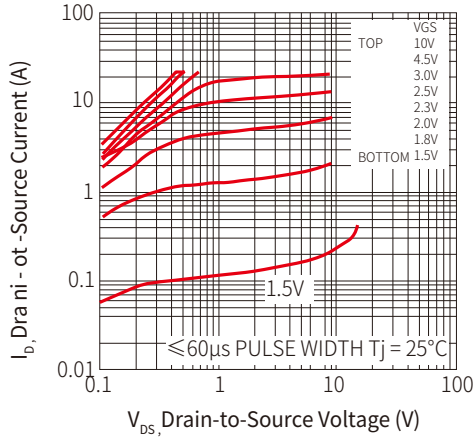
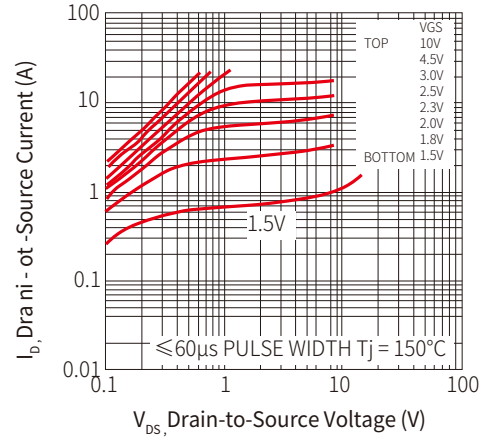
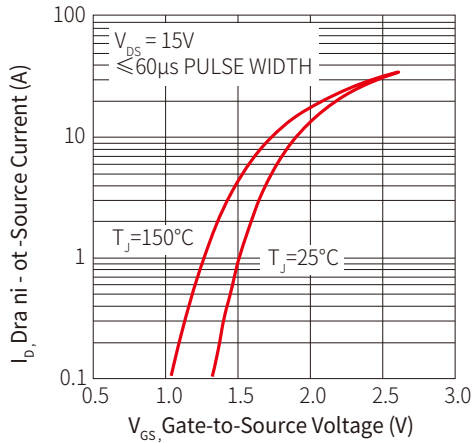
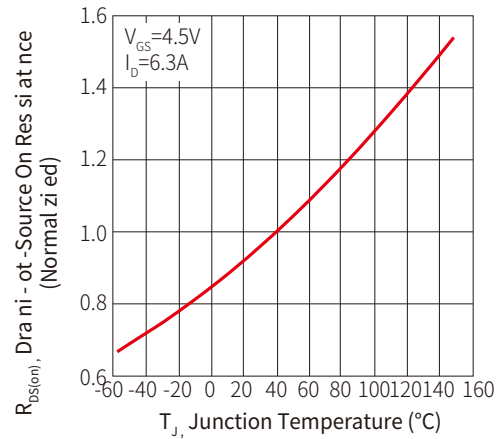
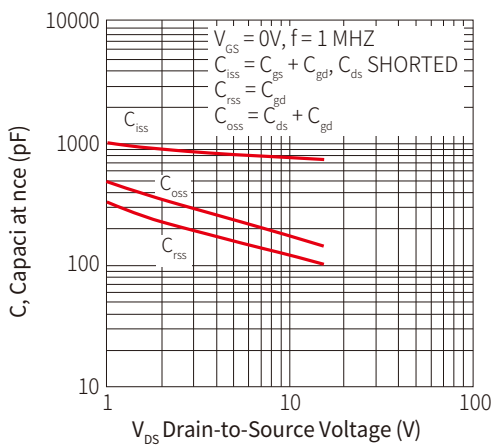
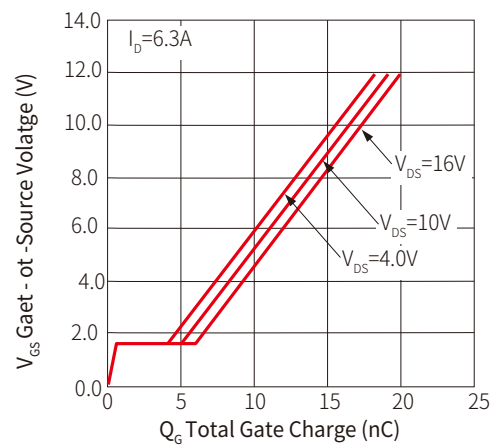
Figure 6: Typical Gate Charge Vs. Gate-to-Source Voltage

Figure 7: Typical Source-Drain Diode Forward Voltage

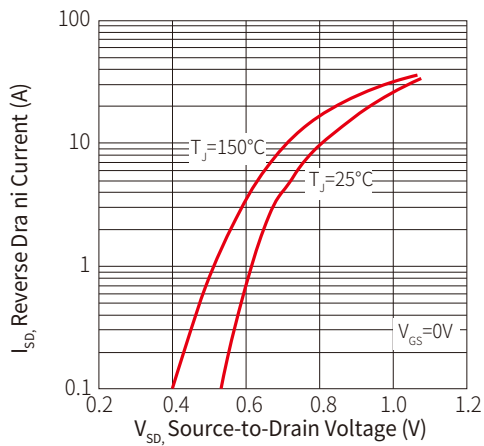

Figure 8: Maximum Safe Operating Area

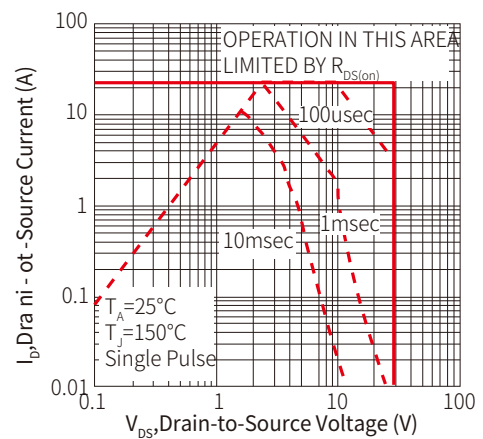

Figure 9: Maximum Drain Current Vs. Ambient Temperature

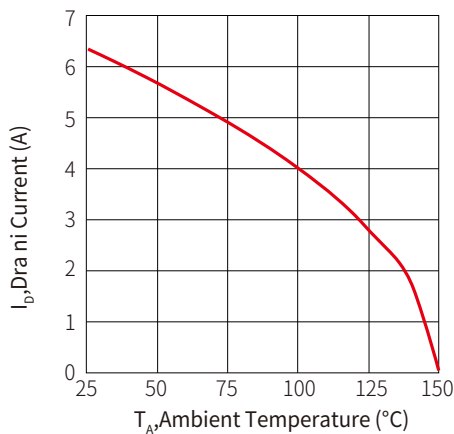

Figure 10: Typical On-Resistance Vs. Gate Voltage

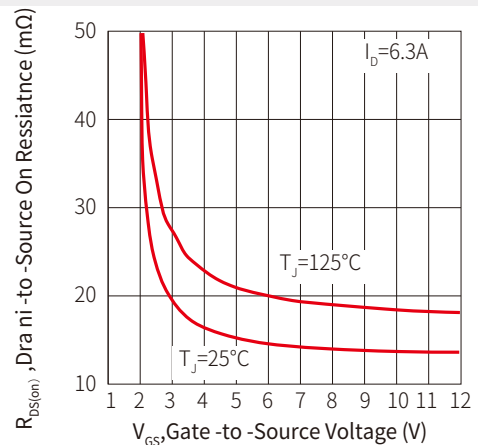

Figure 11: Typical On-Resistance Vs. Drain Current

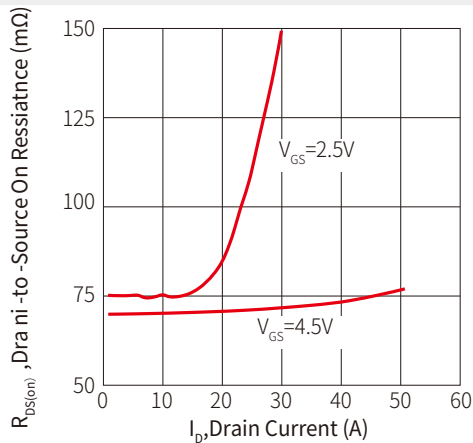

Figure 12: Typical Threshold Voltage Vs. Junction Temperature

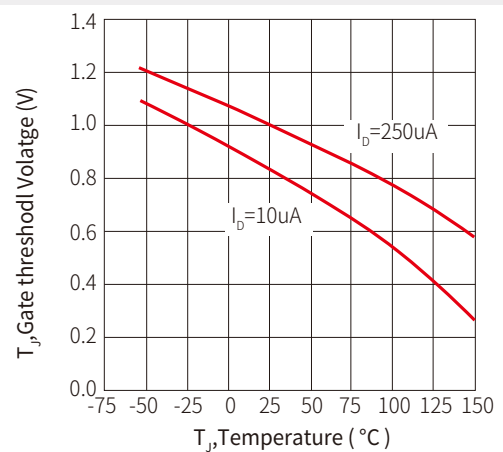

Figure 13: Typical Power Vs. Time

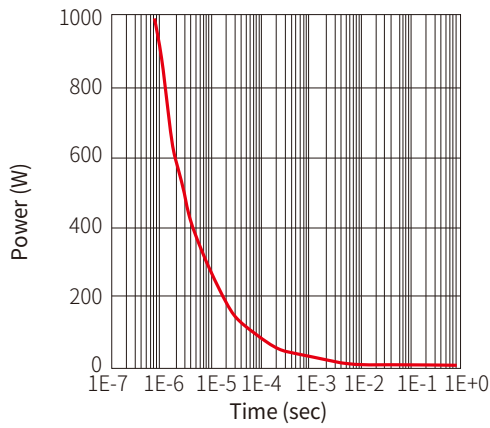

Figure 14: Typical Effective Transient Thermal Impedance, Junction-to-Ambient

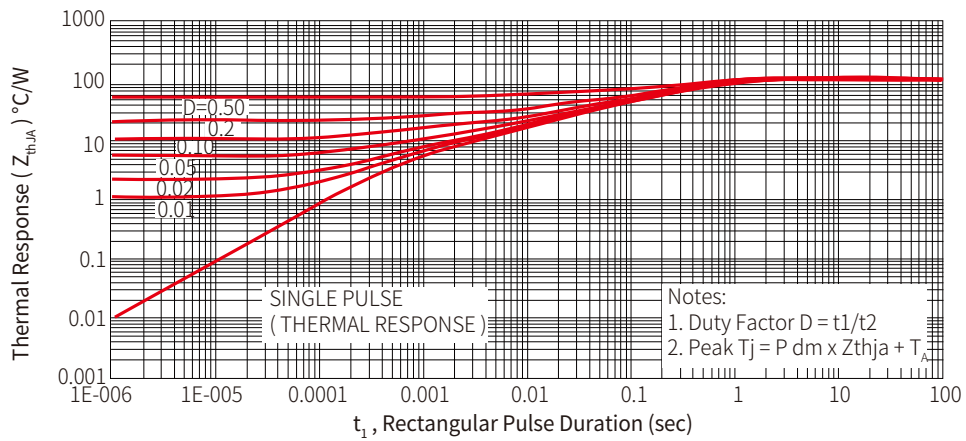

Figure 15: Switching Time Test Circuit & Waveforms

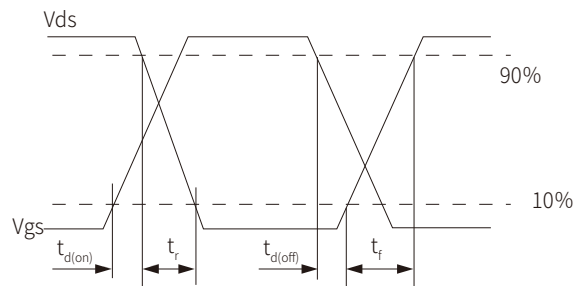
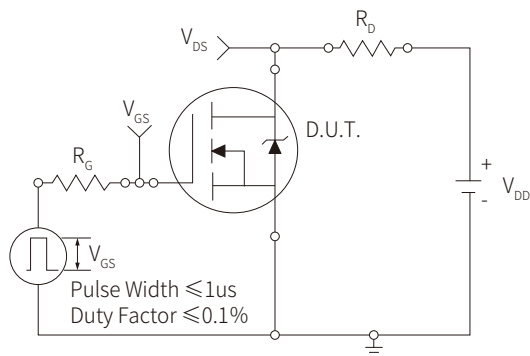
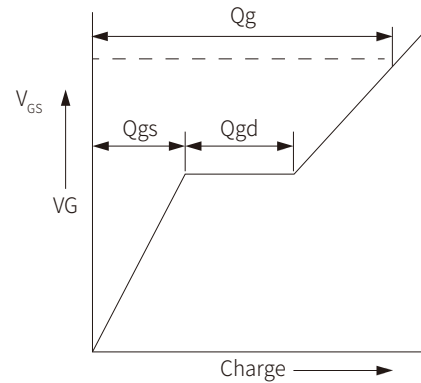
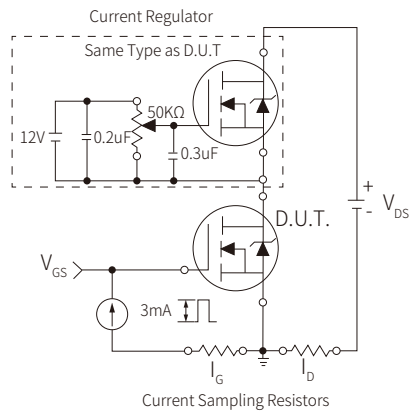
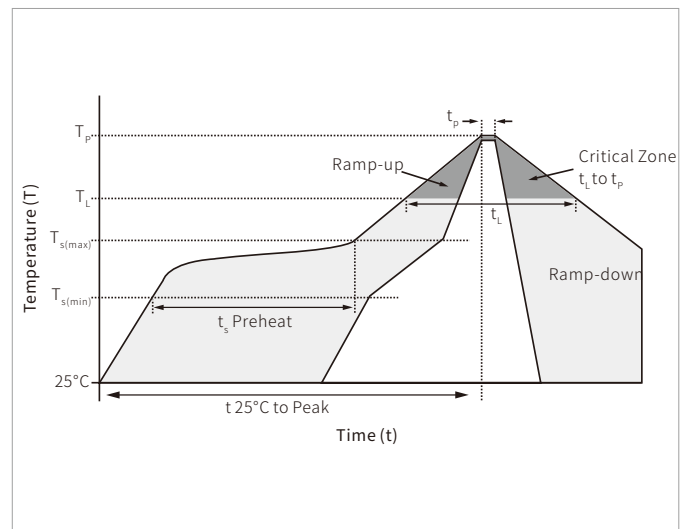

Figure 16: Basic Gate Charge Waveform & Test Circuit

SOLDERING PARAMETERS

Reflow Condition		Lead-free assembly
Pre Heat	Temperature Max ($T_{s(min)}$)	150°C
	Temperature Max ($T_{s(max)}$)	200°C
	Time (min to max) (t_s)	60 – 180 secs
Average ramp up rate (Liquidus Temp (T_L) to peak)		3°C/second max
$T_{s(max)}$ to T_L - Ramp-up Rate		3°C/second max
Reflow	Temperature (T_L) (Liquidus)	217°C
	Time (min to max) (t_r)	60 – 150 seconds
Peak Temperature (T_p)		260°C
Time within 5°C of actual peak Temperature (t_p)		20 – 40 seconds
Ramp-down Rate		6°C/second max
Time 25°C to peak Temperature (T_p)		8 minutes max.
Do not exceed		260°C



SOT-23 PACKAGE INFORMATION

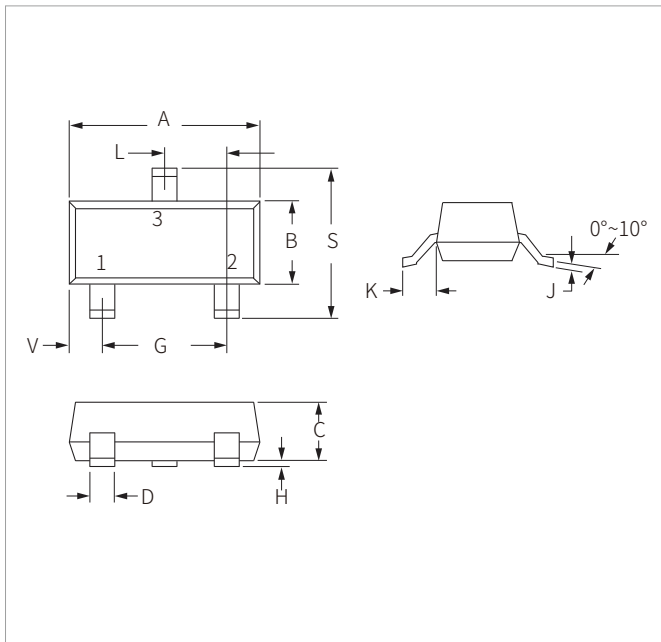

Ref.	Millimeters		Inches	
	Min.	Max.	Min.	Max.
A	2.80	3.05	0.110	0.120
B	1.20	1.40	0.047	0.055
C	0.90	1.15	0.035	0.045
D	0.37	0.50	0.015	0.020
G	1.75	2.05	0.069	0.081
H	0.01	0.100	0.001	0.004
J	0.085	0.180	0.003	0.007
K	0.35	0.69	0.014	0.029
L	0.89	1.02	0.035	0.040
S	2.10	2.65	0.083	0.104
V	0.45	0.60	0.018	0.024

RECOMMENDED PAD LAYOUT DIMENSIONS

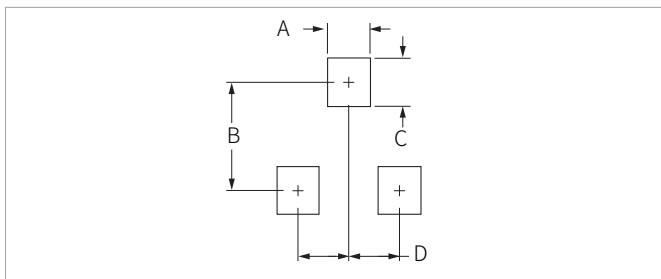

Ref.	Millimeters		Inches	
	Min.	Max.	Min.	Max.
A	0.71	0.97	0.028	0.038
B	1.88	2.13	0.074	0.084
C	0.71	0.97	0.028	0.038
D	0.81	1.07	0.032	0.042

ORDERING INFORMATION

Part Number	Component Package	QTY/Reel	Reel Size
SNM6244S	SOT-23	3000PCS	7"

Headquarters

No.3387 Shendu Road
Pujiang I&E Park
Minhang Shanghai China
201000

Hotline

400-021-5756

Web

<https://www.semiware.com>

Sales Center

Tel: 86-21-3463-7458
Email: sales18@semiware.com

Customer Service

Tel: 86-21-5484-1001
Email: sales17@semiware.com

Technical Support

Tel: 86-21-3463-7654
Email: fae01@semiware.com

Complaint & Suggestions

Tel: 86-21-3463-7172
Ext: 8868
Email: cs03@semiware.com

By QR Code

Website



Wechat

To find your local partner within Semiware' s global website: www.semiware.com

© 2022 Semiware Semiconductor Inc.

The content of this document has been carefully checked and understood. However, neither Semiware nor its subsidiaries assume any liability whatsoever for any errors or inaccuracies of this document and the consequences thereof. Published specifications are subject to change without notice. Product suitability for any area of application must ultimately be determined by the customer. In all cases, products must never be operated outside their published specifications. Semiware does not guarantee the availability of all published products. This disclaimer shall be governed by substantive Chinese law and resulting disputes shall be settled by the courts at the place of business of Semiware. Latest publications and a complete disclaimer can be downloaded from the Semiware website. All trademarks recognized.