

## FEATURES

- | Lead free product is acquired

---

- | Surface mount package

---

- | Moisture Sensitivity Level 3

---

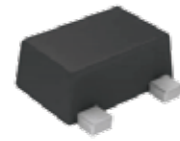
SOT-723

## MECHANICAL DATA

- | SOT-723 Small Outline Plastic Package

---

- | Epoxy UL: 94V-0

---

- | Mounting Position: Any

---

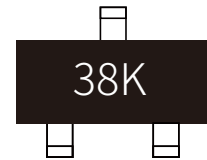
Marking

## APPROVALS

<b>RoHS</b>	Compliance with 2011/65/EU
<b>HF</b>	Compliance with IEC61249-2-21:2003

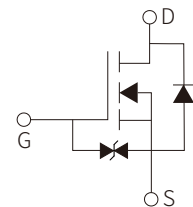

Schematic Symbol

## ABSOLUTE MAXIMUM RATINGS

Parameter	Symbol	Value	Unit
Drain-Source Voltage	$V_{DS}$	50	V
Gate-Source Voltage	$V_{GS}$	$\pm 20$	V
Continuous Drain Current	$I_D$	0.22	A
Power Dissipation	$P_D$	300	mW
Thermal Resistance from Junction to Ambient	$R_{\theta JA}$	417	$^{\circ}C/W$
Junction Temperature	$T_J$	150	$^{\circ}C$
Storage Temperature	$T_{STG}$	-55 to 150	$^{\circ}C$

## ELECTRICAL CHARACTERISTICS (Ta=25°C )

Parameter	Symbol	Test Conditions	Min.	Typ.	Max.	Unit
<b>Static Characteristics</b>						
Drain-Source Breakdown Voltage	$V_{(BR)DSS}$	$V_{GS}=0V, I_D=250\mu A$	50			V
Gate-Body Leakage Current	$I_{GSS}$	$V_{GS}=\pm 20V, V_{DS}=0V$			$\pm 10$	$\mu A$
Zero Gate Voltage Drain Current	$I_{DSS}$	$V_{DS}=50V, V_{GS}=0V$			1	$\mu A$
Gate Threshold Voltage	$V_{GS(th)}$	$V_{DS}=V_{GS}, I_D=250\mu A$	0.5		1.5	V
Drain-source On-Resistance	$R_{DS(on)}$	$V_{GS}=10V, I_D=0.22A$			3.5	$\Omega$
		$V_{GS}=4.5V, I_D=0.22A$			6	$\Omega$
Forward Transconductance <sup>1</sup>	$g_{FS}$	$V_{DS}=10V, I_D=0.2A$	0.12			S
Gate Resistance	$R_g$	f=1MHz, Open drain		69		$\Omega$
<b>Dynamic Characteristics</b>						
Input Capacitance	$C_{iss}$	$V_{DS}=25V, V_{GS}=0V, f=1MHz$		27		pF
Output Capacitance	$C_{oss}$			13		pF
Reverse Transfer Capacitance	$C_{rss}$			6		pF
<b>Switching Characteristics</b>						
Turn-on Delay Time	$t_{d(on)}$	$V_{DD}=30V, I_D=0.29A$ $V_{GS}=10V, R_G=6\Omega$			5	ns
Turn-on Rise Time	$t_r$				18	ns
Turn-Off Delay Time	$t_{d(off)}$				36	ns
Turn-off Fall Time	$t_f$				14	ns
<b>Source-Drain Diode Characteristics</b>						
Diode Forward Voltage	$V_{SD}$	$V_{GS}=10V, I_S=0.2A$			1.3	V
Reverse Recovery Time	$t_{rr}$	$I_S=0.5A, di/dt=100A/us$		8.8		ns
Reverse Recovery Charge	$Q_{rr}$			2.6		nC

# PARAMETER CHARACTERISTIC CURVE

**Figure1: Output Characteristics**

**Figure2: Transfer Characteristics**

**Figure3:  $R_{DS(ON)}$  —  $I_D$** 

**Figure 4:  $R_{DS(ON)}$  —  $V_{GS}$** 

Figure 5:  $I_s$  —  $V_{SD}$

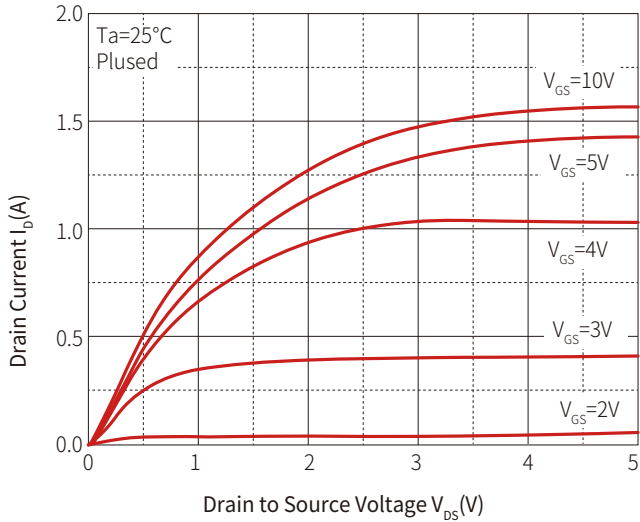
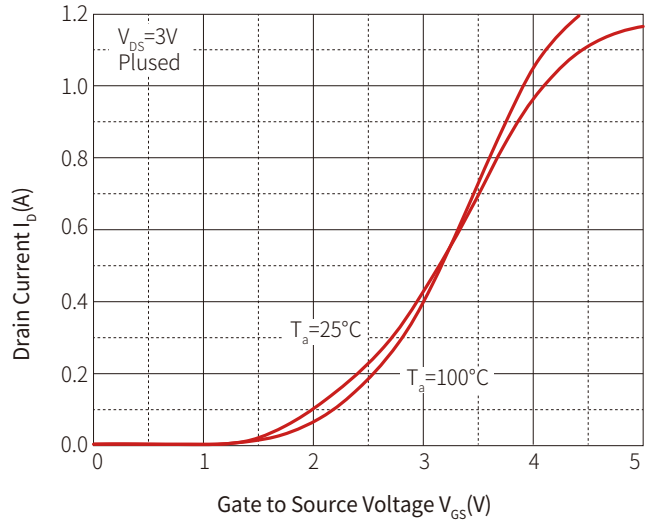
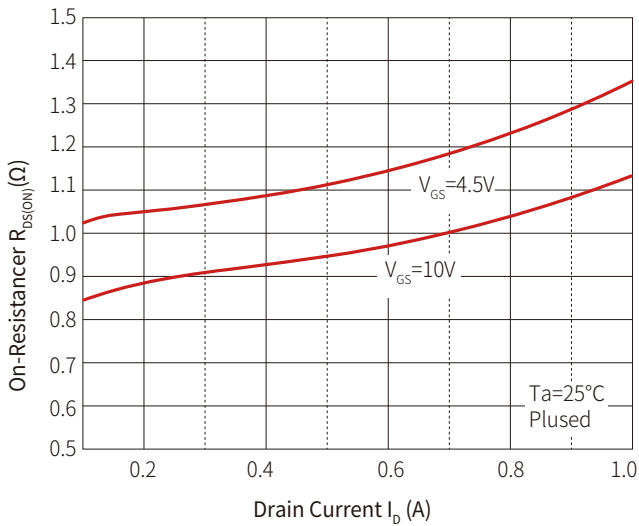
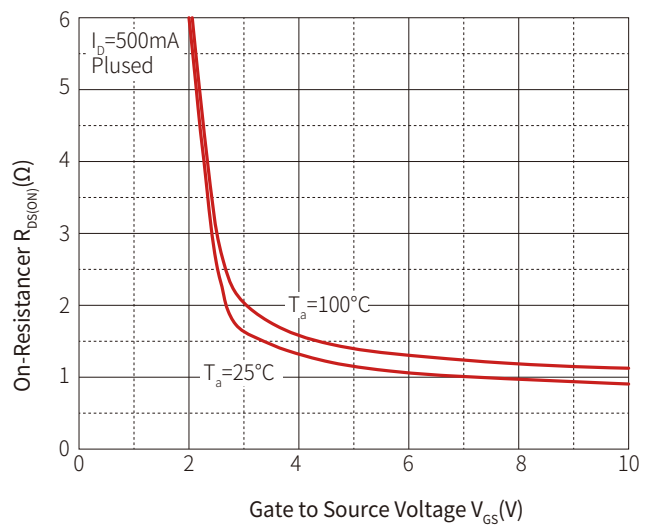
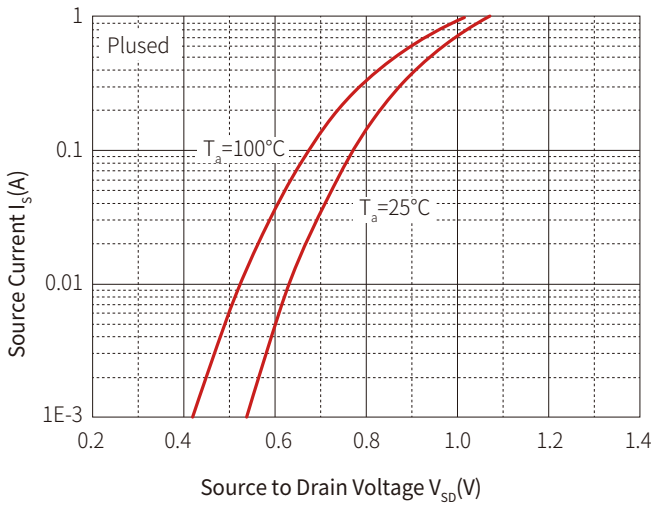
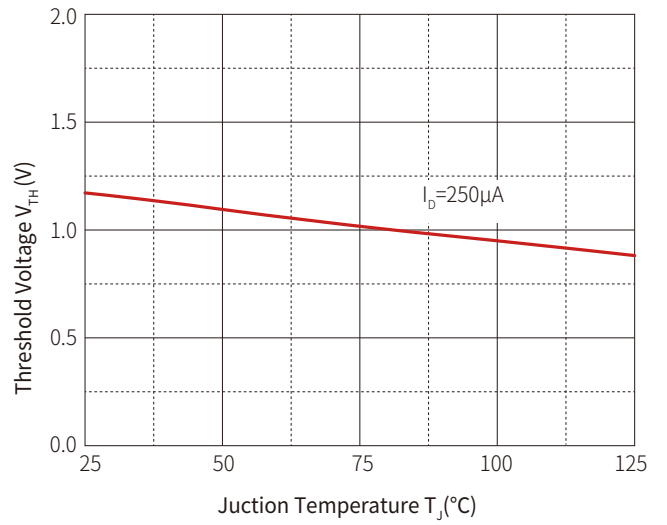
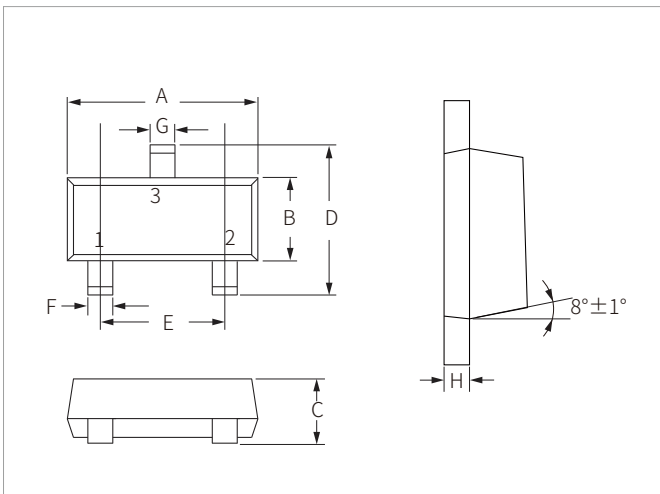

Figure 6: Threshold Voltage



## SOT-723 PACKAGE INFORMATION



Ref.	Millimeters		Inches	
	Min.	Max.	Min.	Max.
A	1.15	1.35	0.045	0.053
B	0.75	0.85	0.030	0.033
C	0.35	0.45	0.014	0.018
D	1.15	1.35	0.045	0.053
E	0.80TYP		0.031TYP	
F	0.175	0.25	0.007	0.010
G	0.225	0.30	0.009	0.012
H	0.09	0.13	0.003	0.005

## RECOMMENDED PAD LAYOUT DIMENSIONS

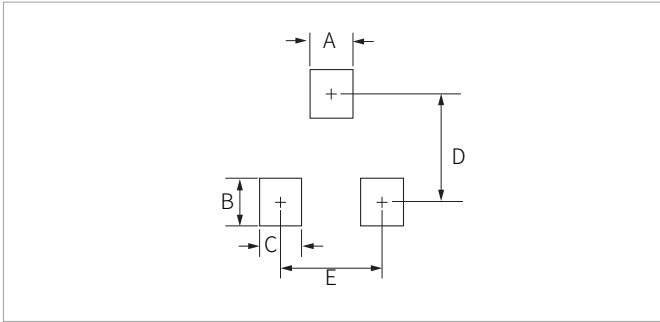

Ref.	Millimeters	Inches
	Dimensions	Dimensions
A	0.50	0.020
B	0.45	0.018
C	0.40	0.016
D	1.15	0.045
E	0.80	0.031

## ORDERING INFORMATION

Part Number	Component Package	QTY/Reel	Reel Size
SNMBSS138ES	SOT-723	8000PCS	7"

**Headquarters**

No.3387 Shendu Road  
Pujiang I&E Park  
Minhang Shanghai China  
201000

**Hotline**

400-021-5756

**Web**

<https://www.semiware.com>

**Sales Center**

Tel: 86-21-3463-7458  
Email: [sales18@semiware.com](mailto:sales18@semiware.com)

**Customer Service**

Tel: 86-21-5484-1001  
Email: [sales17@semiware.com](mailto:sales17@semiware.com)

**Technical Support**

Tel: 86-21-3463-7654  
Email: [fae01@semiware.com](mailto:fae01@semiware.com)

**Complaint & Suggestions**

Tel: 86-21-3463-7172  
Ext: 8868  
Email: [cs03@semiware.com](mailto:cs03@semiware.com)

**By QR Code**

Website



Wechat

To find your local partner within Semiware' s global website: [www.semiware.com](http://www.semiware.com)

© 2022 Semiware Semiconductor Inc.

The content of this document has been carefully checked and understood. However, neither Semiware nor its subsidiaries assume any liability whatsoever for any errors or inaccuracies of this document and the consequences thereof. Published specifications are subject to change without notice. Product suitability for any area of application must ultimately be determined by the customer. In all cases, products must never be operated outside their published specifications. Semiware does not guarantee the availability of all published products. This disclaimer shall be governed by substantive Chinese law and resulting disputes shall be settled by the courts at the place of business of Semiware. Latest publications and a complete disclaimer can be downloaded from the Semiware website. All trademarks recognized.