

FEATURES

- | Low Gate Charge

- | Low ON Resistance

- | Improved dv/dt Capability

- | 100% Avalanche Tested

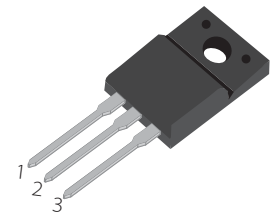
TO-220F

APPLICATION

- | Switching Mode Power Supplies (SMPS)

- | PWM Motor Controls

- | AC to DC Converters

- | LED Lighting

- | Adapter

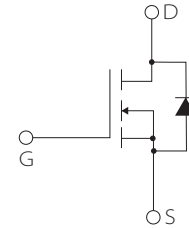
Schematic Symbol

APPROVALS

RoHS	Compliance with 2011/65/EU
HF	Compliance with IEC61249-2-21:2003

ABSOLUTE MAXIMUM RATINGS (T_A=25°C)

Parameter	Symbol	Value	Unit
Drain-Source Voltage	V _{DSS}	650	V
Continuous Drain Current	I _D	T _C =25°C	7 ⁽¹⁾
		T _C =100°C	4.4 ⁽¹⁾
Drain current pulsed ⁽²⁾	I _{DM}	28 ⁽¹⁾	A
Gate-Source Voltage	V _{GS}	±30	V
Single pulsed Avalanche Energy ⁽³⁾	E _{AS}	343	mJ
Peak diode Recovery dv/dt ⁽⁴⁾	dv/dt	5	V/ns
Total power dissipation (@T _C =25°C)	P _D	39	W
Derating Factor above 25°C	P _D	0.3	W/°C
Operating Junction Temperature & Storage Temperature	T _{STG} , T _J	-55 to +150	°C
Maximum lead temperature for soldering purpose	T _L	260	°C
Thermal resistance, Junction to case (Maximum)	R _{thjc}	3.2	°C/W
Thermal resistance, Junction to ambient (Maximum)	R _{thja}	67	°C/W

Notes

1. Drain current is limited by maximum junction temperature.
 3. L = 12mH, I_{AS} = 3A, V_{DD} = 50V, R_G = 25Ω, Starting at T_J = 25°C

2. Repetitive rating : pulse width limited by junction temperature.
 4. I_{SD} ≤ I_D, di/dt = 100A/us, V_{DD} ≤ BV_{DSS}, Starting at T_J = 25°C

ELECTRICAL CHARACTERISTICS (T_A=25°C)

Parameter	Symbol	Test Conditions	Min.	Typ.	Max.	Unit
Off Characteristics						
Drain-source Breakdown Voltage	V _{(BR)DSS}	V _{GS} =0V, I _D =250μA	650			V
Breakdown voltage temperature coefficient	ΔBV _{DSS} / ΔT _J	I _D =250uA, referenced to 25°C		0.65		V/°C
Zero Gate Voltage Drain current	I _{DSS}	V _{DS} =650V, V _{GS} =0V			1	uA
		V _{DS} =520V, T _C =125°C			50	uA
Gate Leakage Current	I _{GSS}	V _{GS} =30V, V _{DS} =0V			100	nA
		V _{GS} =-30V, V _{DS} =0V			-100	nA
Off Characteristics						
Gate Threshold Voltage	V _{GS(th)}	V _{DS} =V _{GS} , I _D =250μA	2.5	3.5	4.5	V
Drain-Source On-Resistance (note2)	R _{DS(on)}	V _{GS} =10V, I _D =2A		1.05	1.3	Ω
Forward Tran conductance	gFS	V _{DS} =10V, I _D =2A		8.5		S
Dynamic Characteristics						
Input capacitance	C _{ISS}	V _{DS} = 25V, V _{GS} = 0V, f=1MHz		1243		pF
Output capacitance	C _{OSS}			87		pF
Reverse Transfer capacitance	C _{rss}			6.5		pF
Turn-on Delay Time	td(on)	V _{DS} =325V, I _D =4A, R _G =25Ω V _{GS} =10V		21		ns
Rising time	tf			23		ns
Turn-off Delay Time	td(off)			70		ns
Input capacitance	tf			23		ns
Total gate charge	Q _g	V _{DS} =325V, I _D =4A, V _{GS} =10V		26		nC
Gate-source charge	Q _{gs}			6		nC
Gate-drain charge	Q _{gd}			8.8		nC
Gate Resistance	R _g	V _{DS} =0V, Scan F mode		2.6		Ω
Continuous source current	I _S	Integral reverse p-n Junction diode in the MOSFET			7	A
Pulsed source current	I _{SM}				28	A
Diode forward voltage drop.	V _{SD}	I _S =4A, V _{GS} =0V			13	V
Reverse recovery time	Trr	I _S =4A, V _{GS} =0V, di _f /dt=100A/us	395			ns
Reverse recovery Charge	Qrr		2.6			uC
Peak Reverse Recovery Current	Irrm	I _S =7A, di _f /dt=100A/us	13.5			A

CHARACTERISTIC CURVES

Fig.1 Output characteristics

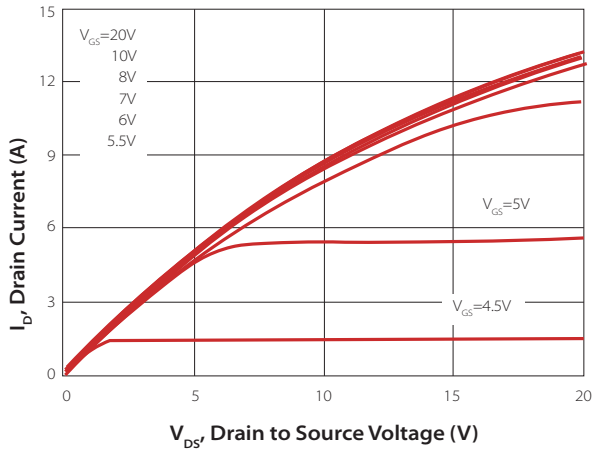

Fig.2 Reverse Characteristics

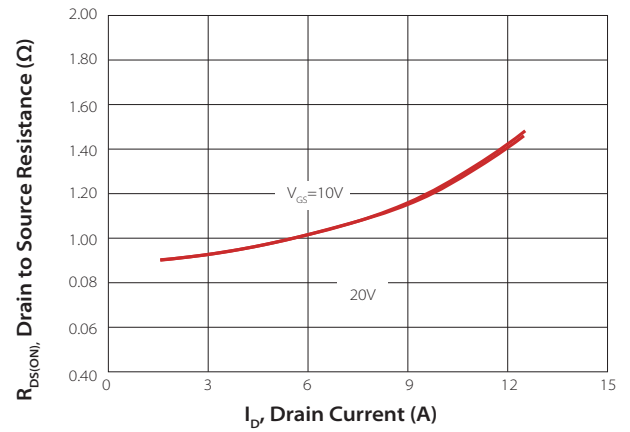

Fig.3 Gate charge characteristics

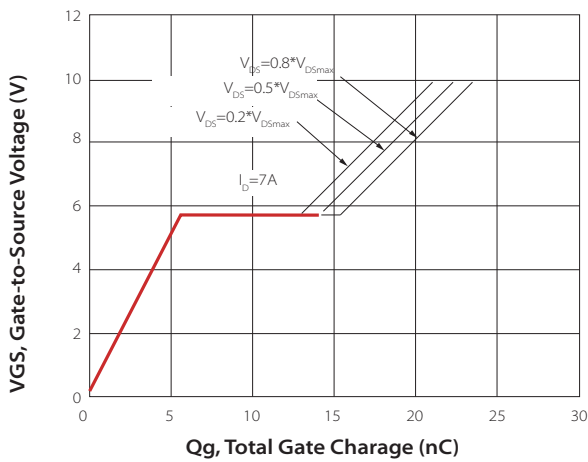

Fig.4 Capacitance Characteristics

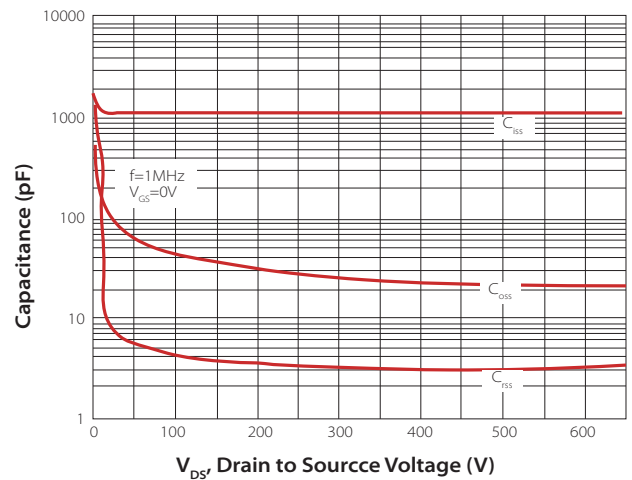

Fig.5 $R_{DS(ON)}$ vs junction temperature

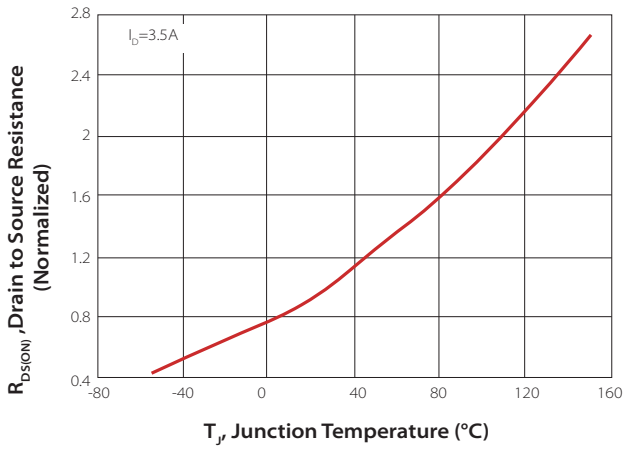

Fig. 6 BV_{DSS} vs junction temperature

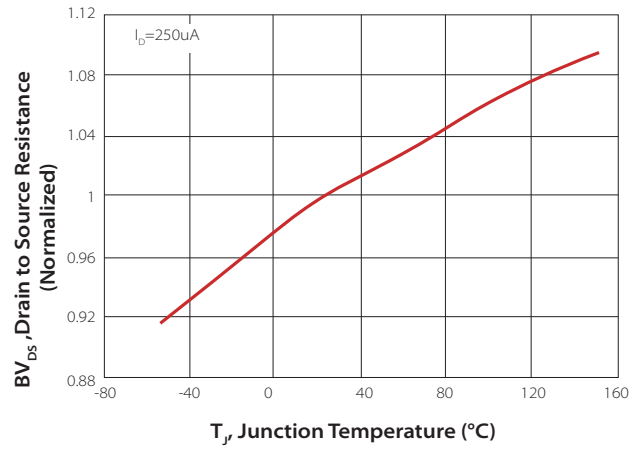

Fig.7 Forward characteristics of reverse diode

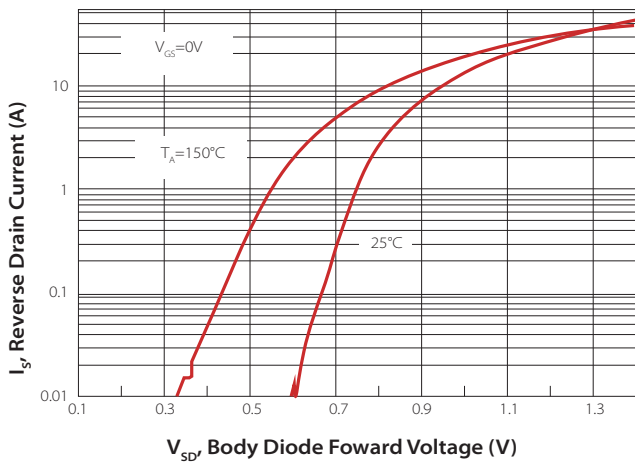

Fig.8 Transfer characteristics

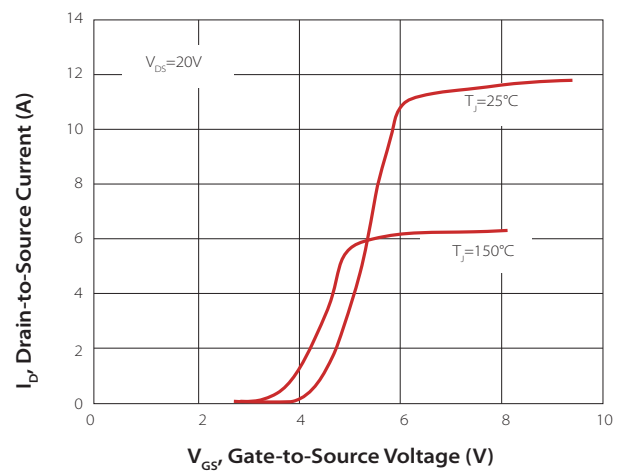

Fig.9 $V_{GS(TH)}$ vs junction temperature

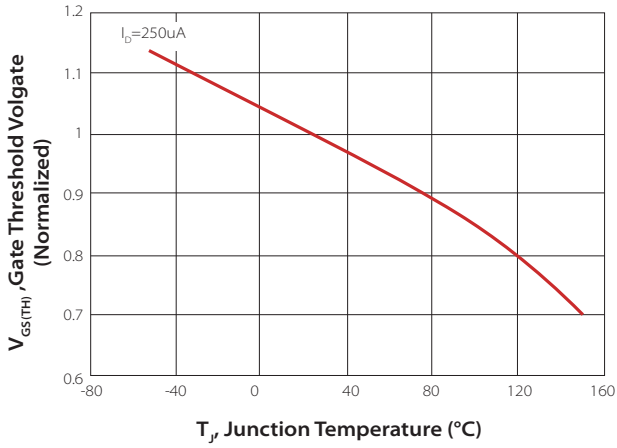

Fig. 10 Safe operating area

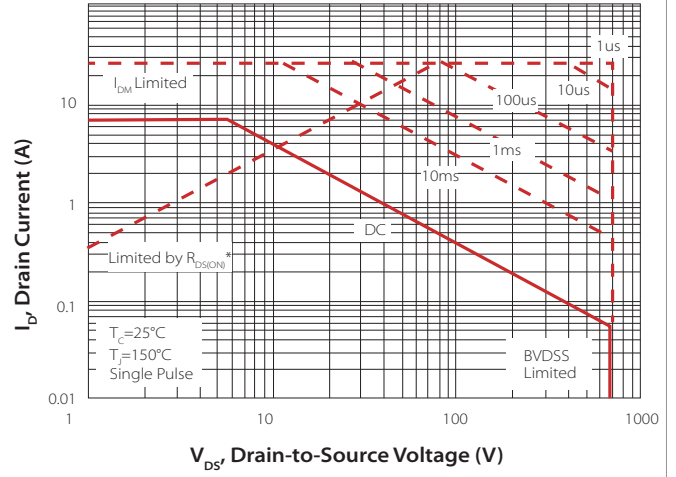

Fig.11 Transient thermal impedance

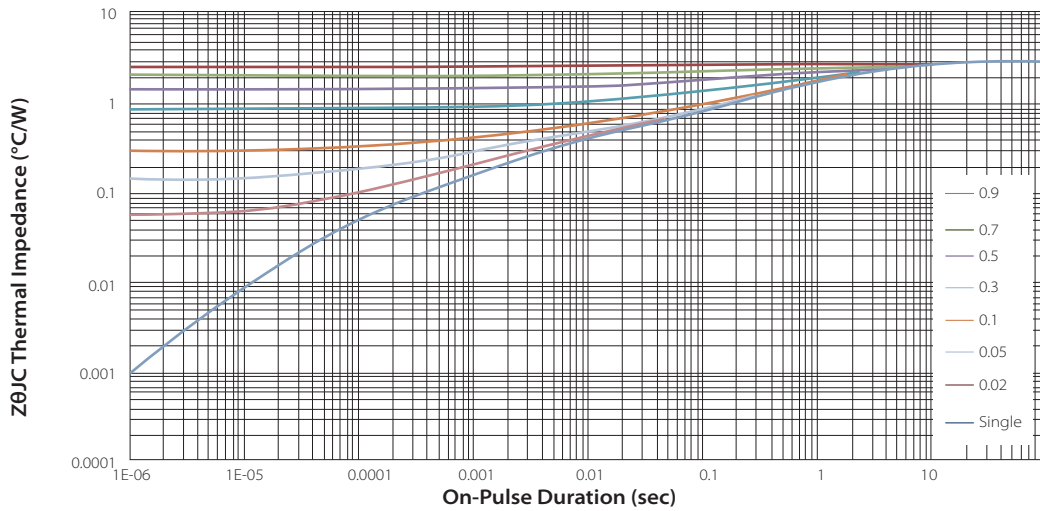

Fig.12 Gate charge test circuit & waveform

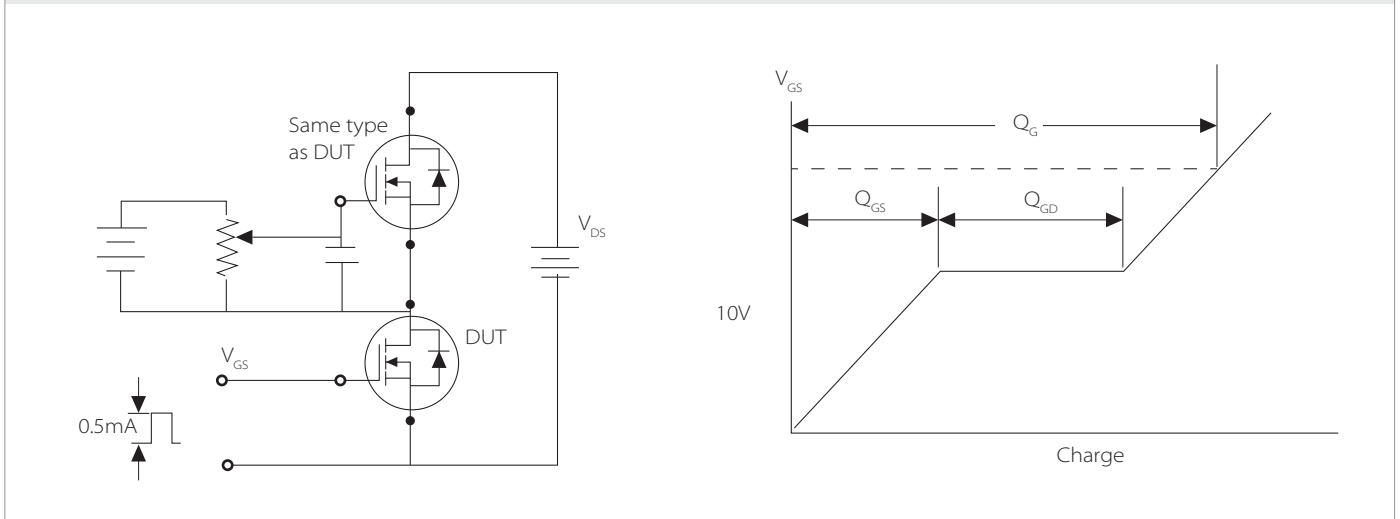

Fig.13 Switching time test circuit & waveform

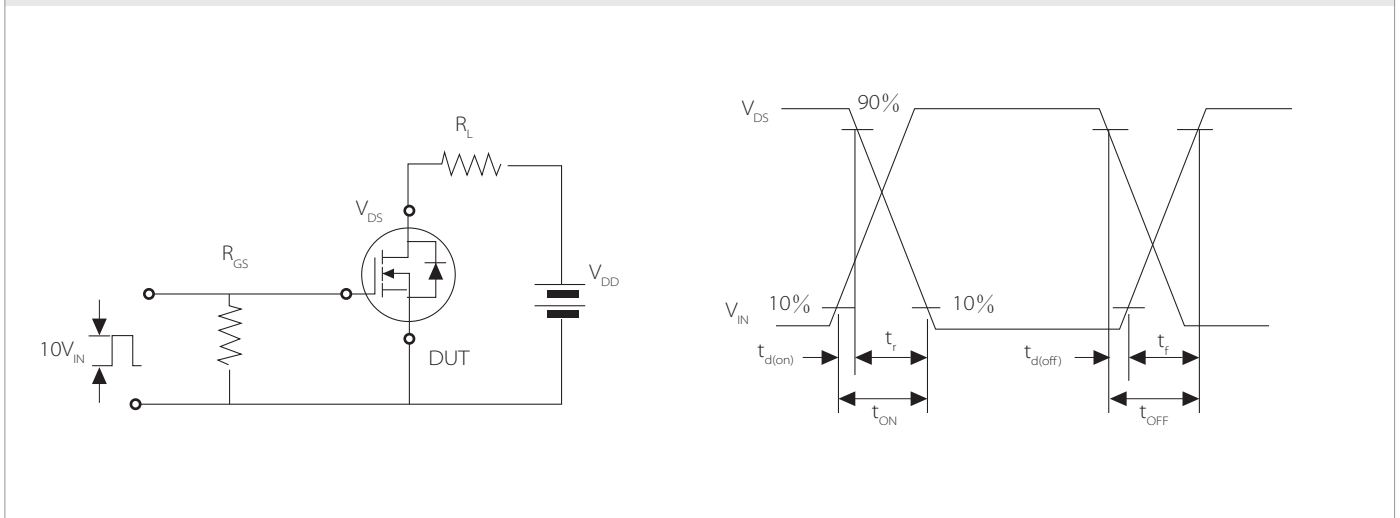

Fig.14 Unclamped Inductive switching test circuit & waveform

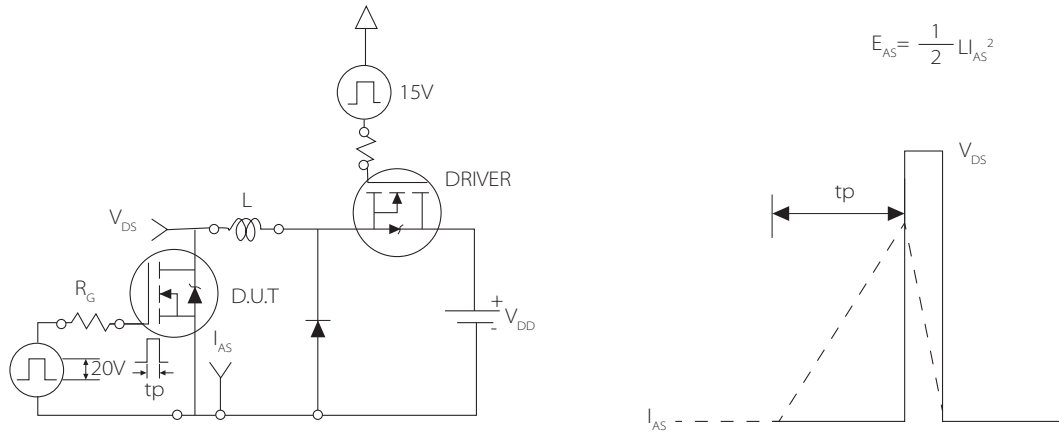
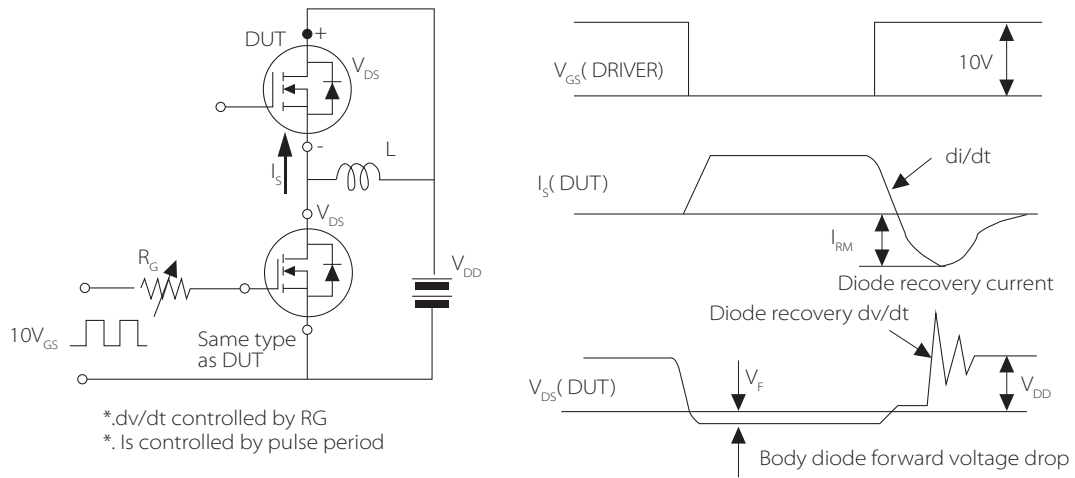
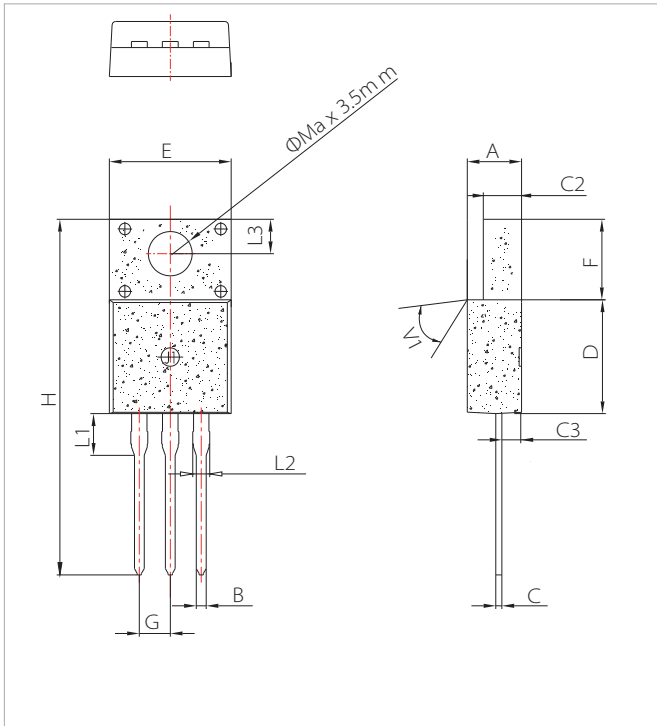

Fig.15 Peak diode recovery dv/dt test circuit & waveform



TO-220F PACKAGE MECHANICAL DATA



Ref.	Dimensions					
	Ref. Millimeters			Inches		
	Min.	Typ.	Max.	Min.	Typ.	Max.
A	4.40		4.80	0.173		0.181
B	0.74	0.80	0.83	0.029		0.033
C	0.48		0.75	0.019		0.030
C2	2.40		2.70	0.094		0.106
C3	2.60		3.00	0.102		0.118
D	8.80		9.30	0.346		0.366
E	9.70		10.3	0.382		0.406
F	6.40		7.00	0.252		0.276
G		2.54			0.1	
H	28.0		29.8	1.102		1.173
L1		3.63			0.143	
L2	1.14		1.70	0.045		0.067
L3		3.30			0.130	
V1		45°			45°	

ORDERING INFORMATION

Part Number	Component Package	Marking	QTY/Tube	Box
SNMF7N65	TO-220F	PDI7N65P2	50PCS	1000PCS

Headquarters

No.3387 Shendu Road Pujiang
I&E Park
Minhang Shanghai China
201000

Hotline

400-021-5756

Web

<https://www.semiware.com>

Sales Center

Tel: 86-21-3463-7458
Email: sales18@semiware.com

Customer Service

Tel: 86-21-5484-1001
Email: sales17@semiware.com

Technical Support

Tel: 86-21-3463-7654
Email: fae01@semiware.com

Complaint & Suggestions

Tel: 86-21-3463-7172
Ext: 8868
Email: cs03@semiware.com

By QR Code

Website



Wechat

To find your local partner within Semiware's global network: www.semiware.com

© 2022 Semiware Semiconductor Inc.

The content of this document has been carefully checked and understood. However, neither Semiware nor its subsidiaries assume any liability whatsoever for any errors or inaccuracies of this document and the consequences thereof. Published specifications are subject to change without notice. Product suitability for any area of application must ultimately be determined by the customer. In all cases, products must never be operated outside their published specifications. Semiware does not guarantee the availability of all published products. This disclaimer shall be governed by substantive Swiss law and resulting disputes shall be settled by the courts at the place of business of Semiware. Latest publications and a complete disclaimer can be downloaded from the Semiware website. All trademarks recognized.