

FEATURES

- | ESD protection for high speed data lines to IEC61000-4-2
- | ESD contact discharge typical 8KV, max 15KV
- | ESD air discharge typical 15KV, max 25KV
- | Surface mount
- | Extremely low capacitance
- | Very low leakage current
- | Fast response time
- | Bi-directional ESD protection
- | Lead free solder termination
- | The best ESD protection for high frequency, low voltage applications



0402



APPLICATIONS

- | USB3.0, Firewire, DVI, HDMI, S-ATA, Thunderbolt
- | Mobile HDMI Link, MDDI, MIPI, SWP/NFC

MECHANICAL DATA

- | Case: 0402 (plastic package)
- | Molding Compound Flammability Rating: UL 94 V-0

APPROVALS

RoHS	Compliance with 2011/65/EU
HF	Compliance with IEC61249-2-21:2003

ABSOLUTE MAXIMUM RATINGS

Symbol	Parameter	Value	Unit
-	Maximum Contact discharge voltage Per IEC61000-4-2	15KV	V
-	Maximum Air discharge voltage Per IEC61000-4-2	25KV	V
T _{OPER}	Maximum Operating temperature	-40 to +90	°C
T _{STG}	Maximum Storage temperature	-55 to +125	°C

ELECTRICAL CHARACTERISTICS (T_A=25°C)

Symbol	Parameter	Test Conditions	Min.	Typ.	Max.	Unit
V _R	Rated Voltage	-	-	-	5	V
V _T	Trigger Voltage	IEC61000-4-2 8KV contact discharge	-	300	-	V
V _C	Clamping Voltage	IEC61000-4-2 8KV contact discharge	-	35	-	V
I _L	Leakage Current	DC 5V shall be applied on component	-	-	0.10	μA
C _P	Capacitance	V _R = 0V, f = 1MHz	-	0.05	-	pF

Note:

1. Trigger and clamping voltage are measured per IEC 61000-4-2, 8KV contact discharge method.
2. After reliability tests such as high temp storage, temp cycles, continuous ESD strike etc, the maximum leakage current is less than 10uA.

ESD CLAMPING TEST

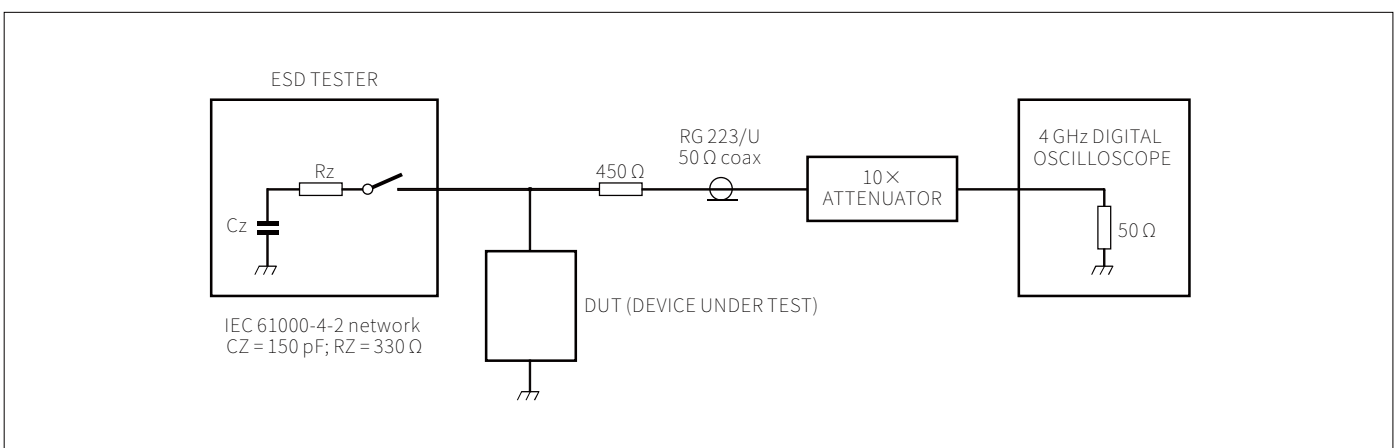

CHARACTERISTIC CURVES

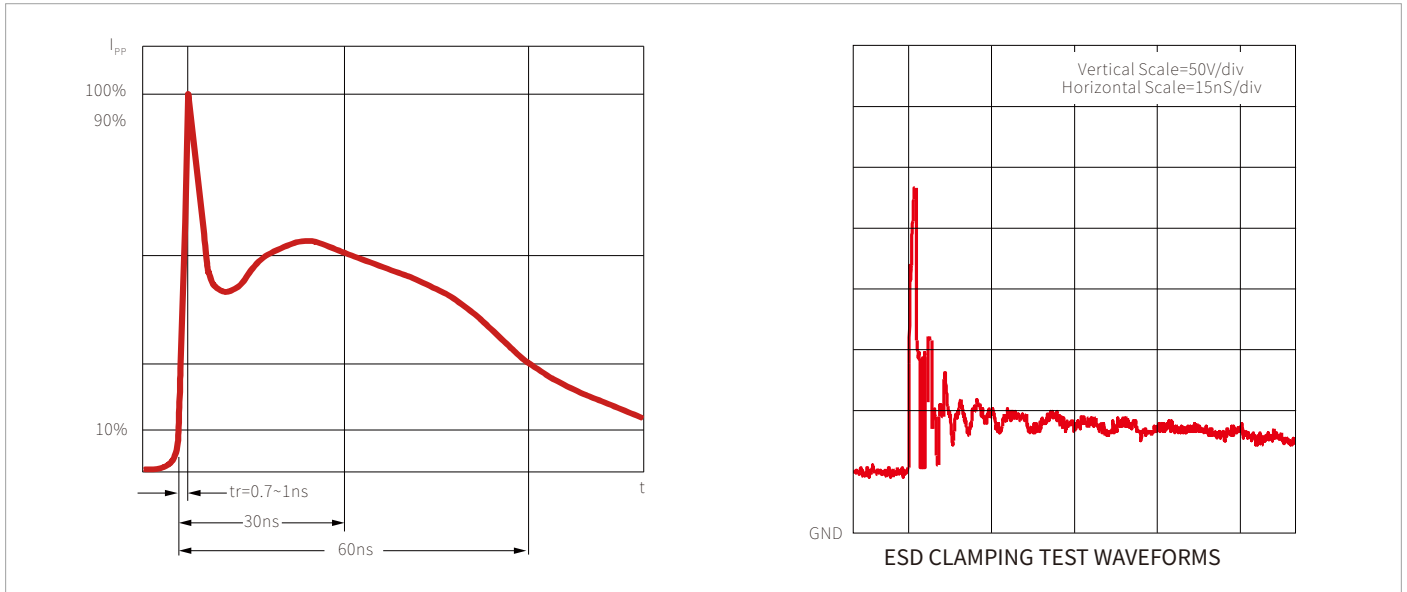

SOLDERING PARAMETERS

Reflow Condition		Lead-free assembly
Pre Heat	Temperature Max ($T_{s(min)}$)	150°C
	Temperature Max ($T_{s(max)}$)	200°C
	Time (min to max) (t_s)	60 – 180 secs
Average ramp up rate (Liquidus Temp (T_L) to peak)		3°C/second max
$T_{s(max)}$ to T_L - Ramp-up Rate		3°C/second max
Reflow	Temperature (T_L) (Liquidus)	217°C
	Time (min to max) (t_r)	60 – 150 seconds
Peak Temperature (T_p)		260°C
Time within 5°C of actual peak Temperature (t_p)		20 – 40 seconds
Ramp-down Rate		6°C/second max
Time 25°C to peak Temperature (T_p)		8 minutes max.
Do not exceed		260°C

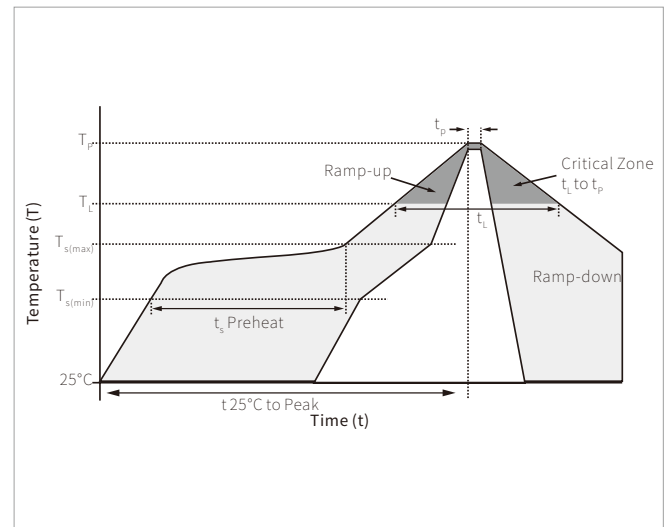

PACKAGE INFORMATION

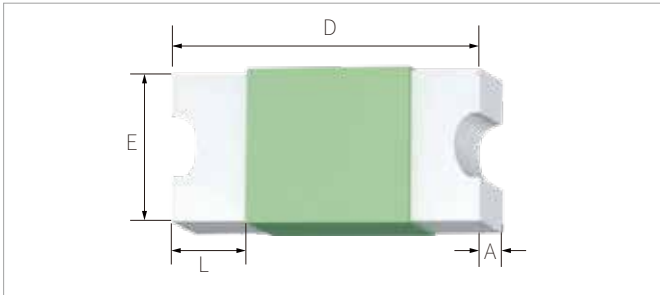

Ref.	Dimension			Unit
	Min.	Typ.	Max.	
D	0.90	1.05	1.20	mm
E	0.45	0.55	0.65	
L	0.15	0.25	0.35	
A	0.25	0.35	0.45	

RECOMMENDED PAD LAYOUT DIMENSIONS

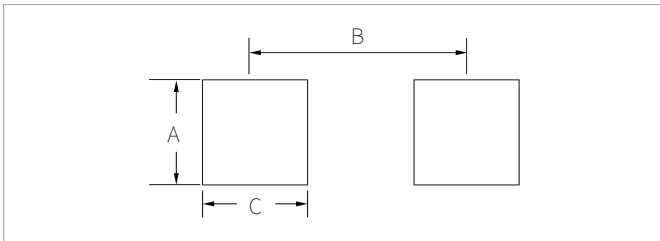

Ref.	Dimension	Unit
A	0.50	mm
B	0.90	
C	0.65	

ORDERING INFORMATION

Part Number	Component Package	QTY/Reel	Reel Size
SPE0402B5.0	0402	10000PCS	7"

Headquarters

No.3387 Shendu Road
Pujiang I&E Park
Minhang Shanghai China
201000

Hotline

400-021-5756

Web

<https://www.semiware.com>

Sales Center

Tel: 86-21-3463-7458
Email: sales18@semiware.com

Customer Service

Tel: 86-21-5484-1001
Email: sales17@semiware.com

Technical Support

Tel: 86-21-3463-7654
Email: fae01@semiware.com

Complaint & Suggestions

Tel: 86-21-3463-7172
Ext: 8868
Email: cs03@semiware.com

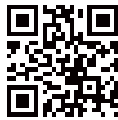
By QR Code

Website



Wechat

To find your local partner within Semiware's global network: www.semiware.com

© 2022 Semiware Semiconductor Inc.

The content of this document has been carefully checked and understood. However, neither Semiware nor its subsidiaries assume any liability whatsoever for any errors or inaccuracies of this document and the consequences thereof. Published specifications are subject to change without notice. Product suitability for any area of application must ultimately be determined by the customer. In all cases, products must never be operated outside their published specifications. Semiware does not guarantee the availability of all published products. This disclaimer shall be governed by substantive Chinese law and resulting disputes shall be settled by the courts at the place of business of Semiware. Latest publications and a complete disclaimer can be downloaded from the Semiware website. All trademarks recognized.