

## FEATURES

- | Surface-mounted package
- | Advanced trench cell design
- | Extremely low threshold voltage
- | ESD 2KV



## APPLICATION

- | Portable appliances

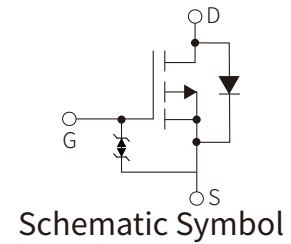

## APPROVALS

<b>RoHS</b>	Compliance with 2011/65/EU
<b>HF</b>	Compliance with IEC61249-2-21:2003

## ABSOLUTE MAXIMUM RATINGS

Parameter	Symbol	Value	Unit
Drain-Source Voltage $T_A=25^\circ\text{C}$	$V_{DS}$	-20	V
Pulsed Drain Current $T_A=25^\circ\text{C}$ $V_{GS}=-4.5\text{V}$	$I_{DM}^{**}$	-2	A
Drain Current $T_A=25^\circ\text{C}$ $V_{GS}=-4.5\text{V}$	$I_D^*$	-0.5	A
Gate-Source Voltage $T_A=25^\circ\text{C}$	$V_{GS}$	$\pm 8$	V
Total Power Dissipation $T_A=25^\circ\text{C}$	$P_{tot}^*$	0.43	W
Diode Forward Current $T_A=25^\circ\text{C}$	$I_S$	-0.5	A
Junction Temperature	$T_J$	150	$^\circ\text{C}$
Storage Temperature	$T_{STG}$	-55 to 150	$^\circ\text{C}$
Thermal Resistance- Junction to Ambient	$R_{\theta JA}^*$	290	$^\circ\text{C/W}$

Notes:

\* Surface Mounted on 1 in<sup>2</sup> pad area,  $t \leq 10$  sec

\*\* Pulse width  $\leq 300 \mu\text{s}$ , duty cycle  $\leq 2\%$

## ELECTRICAL CHARACTERISTICS (T<sub>A</sub>=25°C)

Parameter	Symbol	Test Conditions	Min.	Typ.	Max.	Unit
<b>Static Characteristics</b>						
Drain-source Breakdown Voltage	V <sub>(BR)DSS</sub>	V <sub>GS</sub> =0V, I <sub>DS</sub> =-250μA	-20			V
Gate Threshold Voltage	V <sub>GS(th)</sub>	V <sub>DS</sub> =V <sub>GS</sub> , I <sub>DS</sub> =-250μA	-0.5		-1	V
Drain Leakage Current	I <sub>DSS</sub>	V <sub>DS</sub> =-16V, V <sub>GS</sub> =0V			-1	μA
		V <sub>DS</sub> =-16V, V <sub>GS</sub> =0V, T <sub>J</sub> =85 °C			-30	μA
Gate Leakage Current	I <sub>GSS</sub>	V <sub>GS</sub> =±8V, V <sub>DS</sub> =0V			±10	μA
On-State Resistance	R <sub>DS(on)</sub> <sup>a</sup>	V <sub>GS</sub> =-4.5V, I <sub>DS</sub> =-0.5A		0.7	0.8	Ω
		V <sub>GS</sub> =-2.5V, I <sub>DS</sub> =-0.2A		0.9	1.1	
		V <sub>GS</sub> =-1.8V, I <sub>DS</sub> =-0.1A		1.1	1.5	
<b>Diode Characteristics</b>						
Diode Forward Voltage	V <sub>SD</sub> <sup>a</sup>	I <sub>SD</sub> =-0.5A, V <sub>GS</sub> =0V			-1.1	V
<b>Dynamic Characteristics<sup>b</sup></b>						
Input capacitance	C <sub>iss</sub>	V <sub>GS</sub> =0V, V <sub>DS</sub> =-10V, Frequency = 1 MHz		103		pF
Output capacitance	C <sub>oss</sub>			12		pF
Reverse transfer capacitance	C <sub>rss</sub>			6.7		pF
Turn-on Delay Time	t <sub>d(on)</sub>	V <sub>DS</sub> =-10V, V <sub>GEN</sub> =-4.5V R <sub>G</sub> =4.5Ω, R <sub>L</sub> =20Ω, I <sub>DS</sub> =-0.5A		7.5		nS
Turn-on Rise Time	t <sub>r</sub>			22		nS
Turn-Off Delay Time	t <sub>d(off)</sub>			189		nS
Turn-Off Fall Time	t <sub>f</sub>			115		nS
<b>Gate Charge Characteristics<sup>b</sup></b>						
Total Gate Charge	Q <sub>g</sub>	V <sub>DS</sub> =-10V, V <sub>GS</sub> =-4.5V, I <sub>DS</sub> =-0.5A		1.2		nC
Gate-Source Charge	Q <sub>gs</sub>			0.4		nC
Gate-Drain Charge	Q <sub>gd</sub>			0.2		nC

**Notes:**

a : Pulse test ; pulse width ≤ 300μs, duty cycle ≤ 2 %

b : Guaranteed by design, not subject to production testing

# PARAMETER CHARACTERISTIC CURVE

Figure1: Power Dissipation

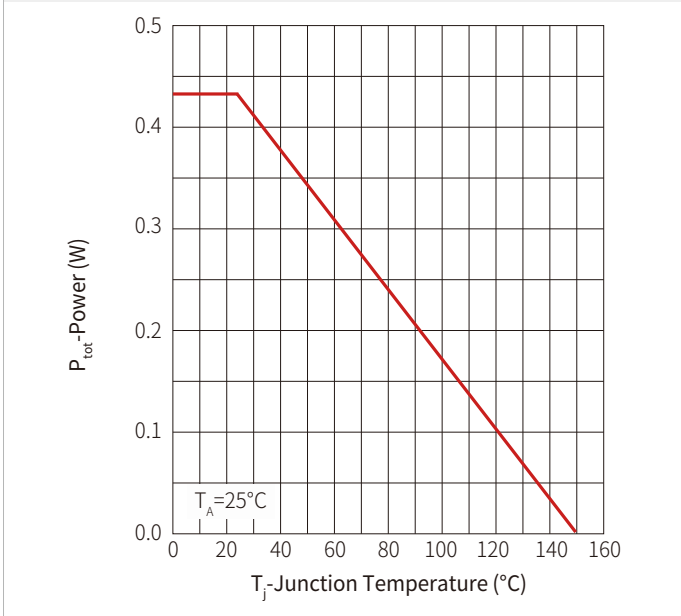

Figure2: Drain Current

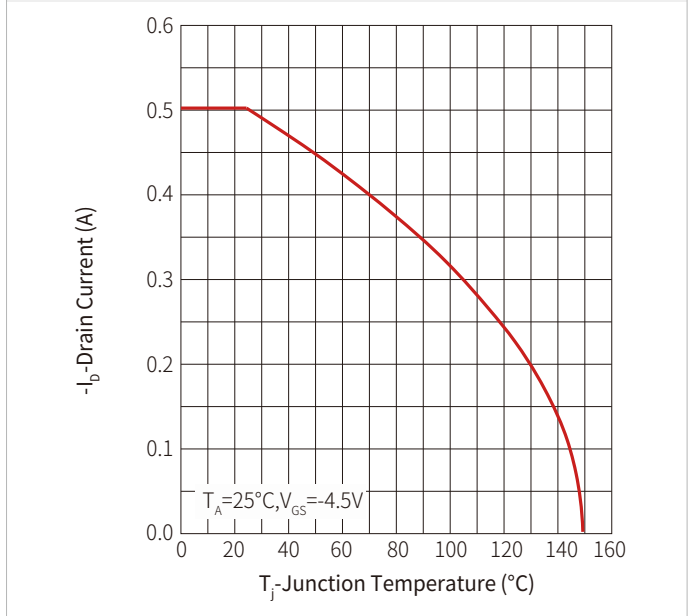

Figure3: Safe Operating Area

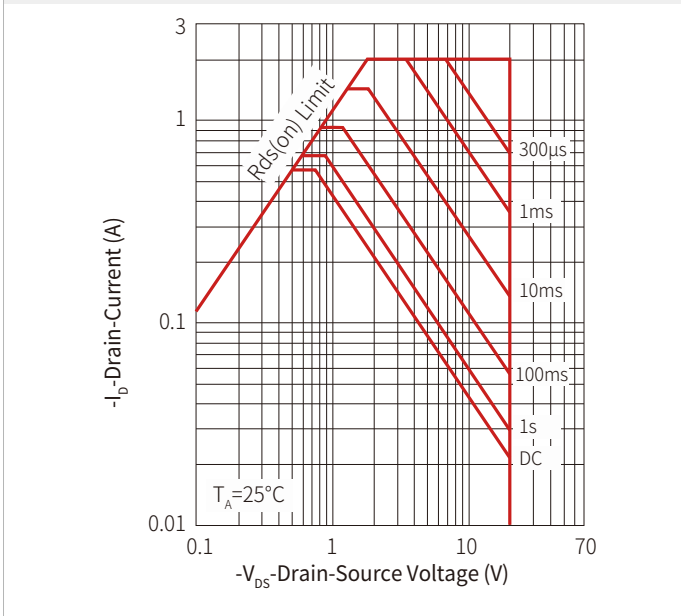
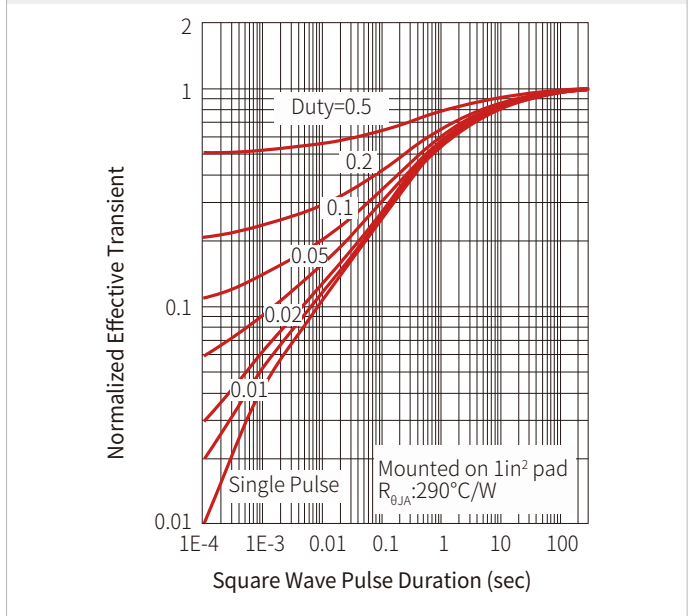
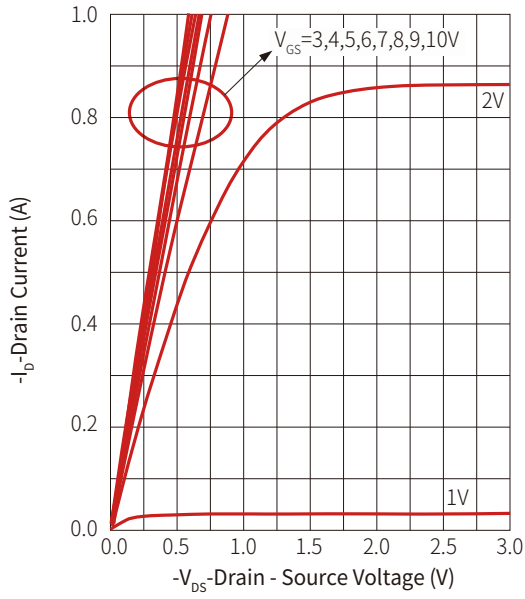

Figure 4: Thermal Transient Impedance



**Figure 5: Output Characteristics**



**Figure 6: Drain-Source On Resistance**

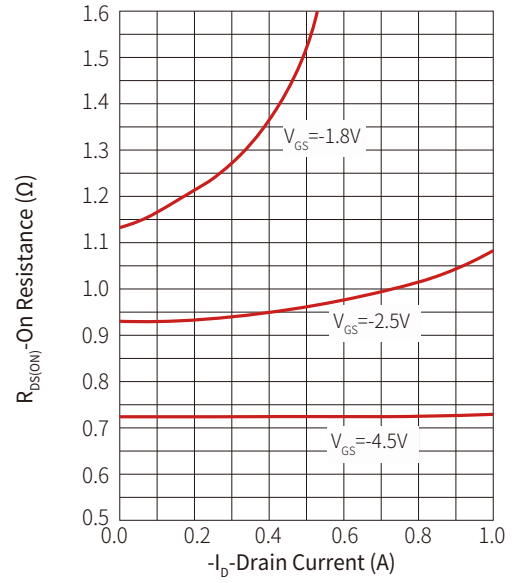

**Figure 7: Transfer Characteristics**

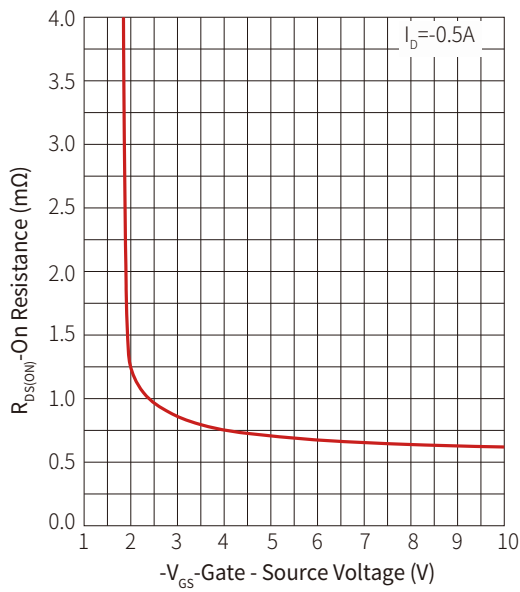

**Figure 8: Gate Threshold Voltage**

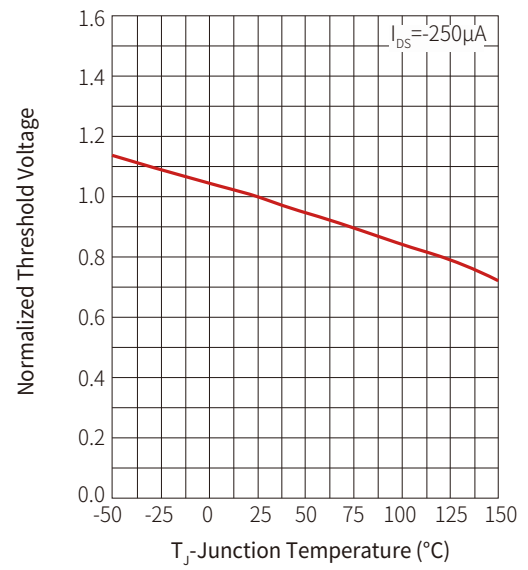

**Figure 9: Drain-Source On Resistance**

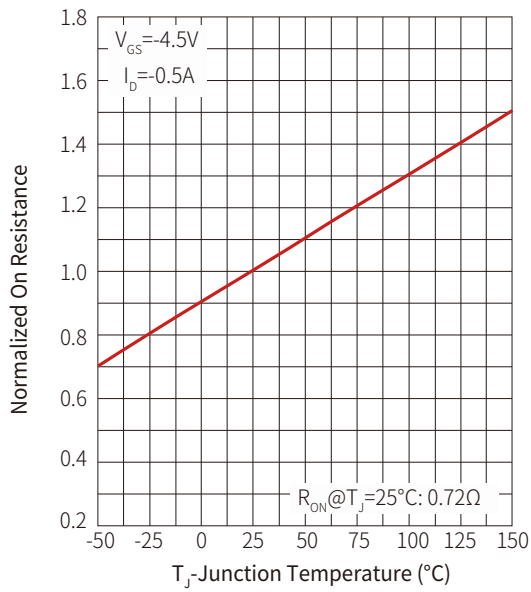

**Figure 10: Source-Drain Diode Forward**

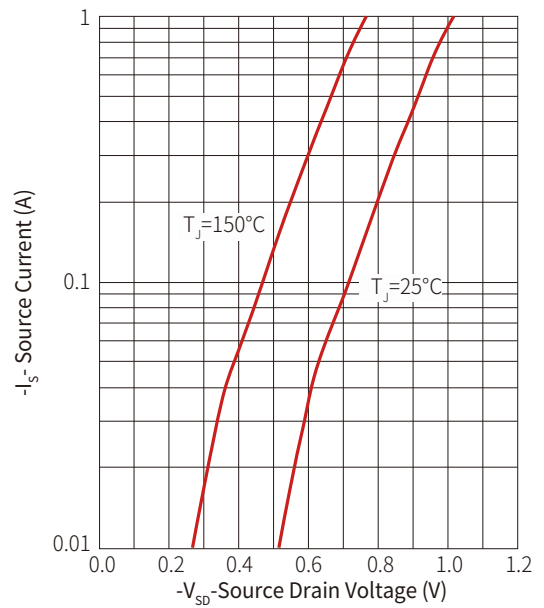

**Figure 11: Capacitance**

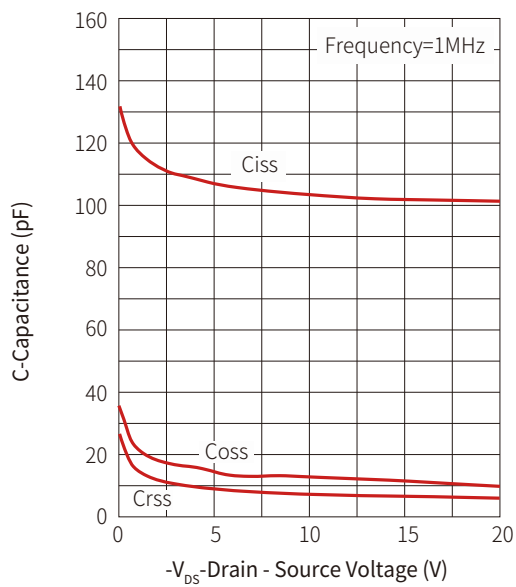

**Figure 12: Gate Charge**

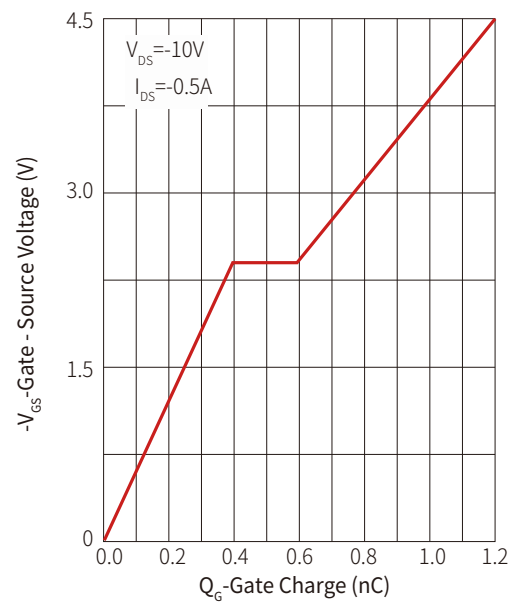

## DFN1006-3L PACKAGE INFORMATION

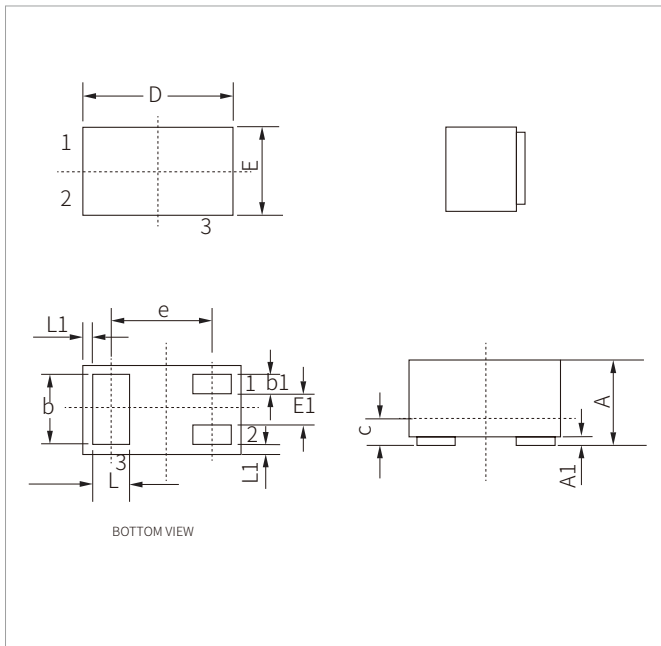

Ref.	Millimeters		Inches	
	Min.	Max.	Min.	Max.
A	0.35	0.60	0.014	0.024
A1	0	0.05	0	0.002
b	0.45	0.55	0.018	0.022
b1	0.10	0.20	0.004	0.008
c	0.12	0.18	0.005	0.007
D	0.95	1.05	0.037	0.041
e	0.65BSC		0.026BSC	
E	0.55	0.70	0.022	0.027
E1	0.20	0.30	0.008	0.014
L	0.20	0.30	0.008	0.012
L1	0.05REF		0.002REF	

## RECOMMENDED PAD LAYOUT DIMENSIONS

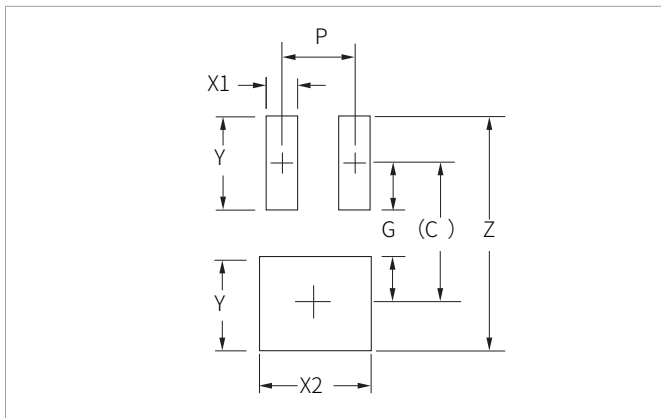

Ref.	Millimeters	Inches
C	(0.85)	(0.033)
P	0.40	0.016
G	0.30	0.012
X1	0.20	0.008
X2	0.60	0.024
Y	0.55	0.022
Z	1.40	0.055

## ORDERING INFORMATION

Part Number	Component Package	QTY/Reel	Reel Size
SPM850P02K	DFN1006-3L	10000PCS	7"

**Headquarters**

No.3387 Shendu Road  
Pujiang I&E Park  
Minhang Shanghai China  
201000

**Hotline**

400-021-5756

**Web**

<https://www.semiware.com>

**Sales Center**

Tel: 86-21-3463-7458  
Email: [sales18@semiware.com](mailto:sales18@semiware.com)

**Customer Service**

Tel: 86-21-5484-1001  
Email: [sales17@semiware.com](mailto:sales17@semiware.com)

**Technical Support**

Tel: 86-21-3463-7654  
Email: [fae01@semiware.com](mailto:fae01@semiware.com)

**Complaint & Suggestions**

Tel: 86-21-3463-7172  
Ext: 8868  
Email: [cs03@semiware.com](mailto:cs03@semiware.com)

**By QR Code**

Website



Wechat

To find your local partner within Semiware's global website: [www.semiware.com](http://www.semiware.com)

© 2022 Semiware Semiconductor Inc.

The content of this document has been carefully checked and understood. However, neither Semiware nor its subsidiaries assume any liability whatsoever for any errors or inaccuracies of this document and the consequences thereof. Published specifications are subject to change without notice. Product suitability for any area of application must ultimately be determined by the customer. In all cases, products must never be operated outside their published specifications. Semiware does not guarantee the availability of all published products. This disclaimer shall be governed by substantive Chinese law and resulting disputes shall be settled by the courts at the place of business of Semiware. Latest publications and a complete disclaimer can be downloaded from the Semiware website. All trademarks recognized.