

## FEATURES

- | Guardring for overvoltage protection
- | Low power loss
- | Extremely fast switching
- | High forward surge capability
- | High frequency operation

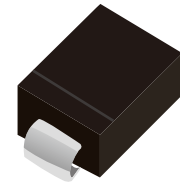

DO-214AA(SMB)

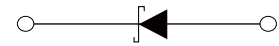

Schematic Symbol

## APPLICATIONS

- | For use in low voltage high frequency.
- | Inverters, freewheeling, DC/DC converters, and polarity protection applications.

## APPROVALS

<b>RoHS</b>	Compliance with 2011/65/EU
<b>HF</b>	Compliance with IEC61249-2-21:2003

## MAXIMUM RATINGS ( $T_A=25^{\circ}\text{C}$ )

Parameter	Symbol	SS 1020B	SS 1030B	SS 1040B	SS 1050B	SS 1060B	SS 1080B	SS 10100B	SS 10150B	SS 10200B	Unit	
Marking		SS 1020	SS 1030	SS 1040	SS 1050	SS 1060	SS 1080	SS 10100	SS 10150	SS 10200		
Maximum Repetitive Peak Reverse Voltage	$V_{RRM}$	20	30	40	50	60	80	100	150	200	V	
Average Rectified Output Current @60Hz Sine Wave, Resistance Load, TL (Fig.1)	$I_O$	10.0									A	
Surge(Non-Repetitive)forward Current @60Hz Half-sine Wave,1 Cycle, $T_A=25^{\circ}\text{C}$	$I_{FSM}$	180.0									A	
Maximum Instantaneous Forward Voltage Drop Per Diode $I_{FM}=10.0\text{A}$	$V_F$	0.55			0.70		0.85		0.95		V	
Maximum DC Reverse Current at Rated DC Blocking Voltage	$T_A=25^{\circ}\text{C}$	0.2					0.1				mA	
	$T_A=100^{\circ}\text{C}$	20					5.0				mA	
Typical Thermal Resistance	$R_{\theta J-A}$	65 <sup>(1)</sup>										$^{\circ}\text{C}/\text{W}$
Typical Thermal Resistance	$R_{\theta J-L}$	8 <sup>(1)</sup>										$^{\circ}\text{C}/\text{W}$
Operating Junction Temperature Range	$T_J$	-55 to +150					-55 to +175					$^{\circ}\text{C}$
Storage Temperature Range	$T_{STG}$	-55 to +150										$^{\circ}\text{C}$

Note (1)

Thermal resistance from junction to ambient and from junction to lead mounted on P.C.B. with 0.6" x 0.6" (16 mm x 16 mm) copper pad areas

# CHARACTERISTIC CURVES

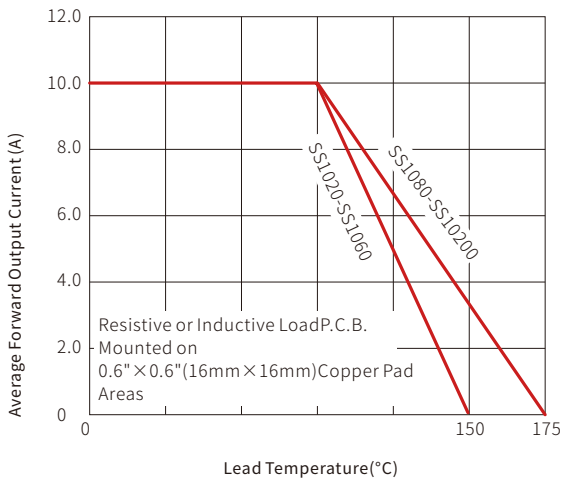
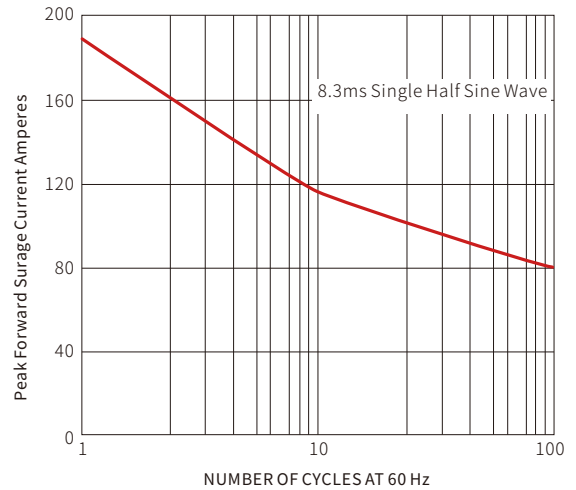
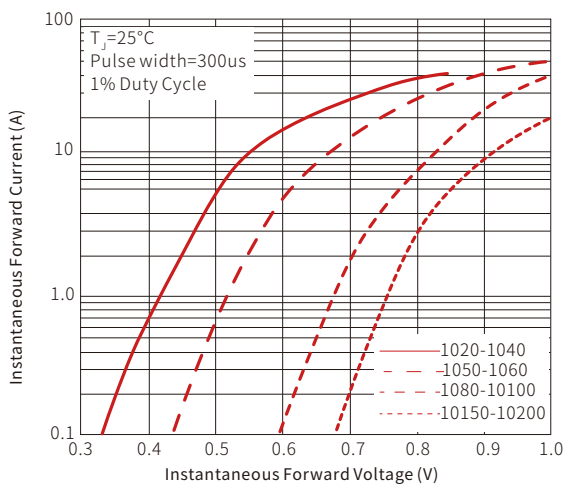
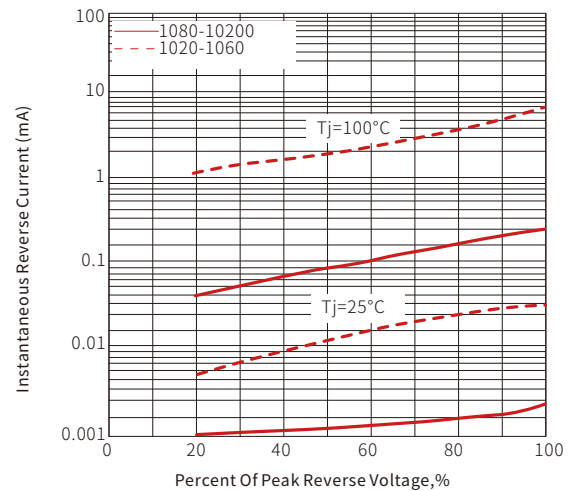
**Fig. 1- I<sub>o</sub>-T<sub>L</sub> Curve**

**Fig. 2- Maximum Non-Repetitive Forward Surge Current**

**Fig. 3- Forward Voltage**

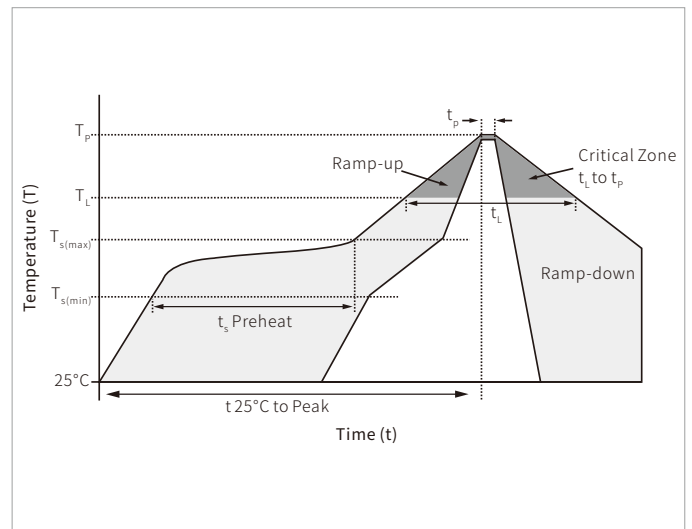
**Fig. 4- Typical Reverse Characteristics**

## SOLDERING PARAMETERS

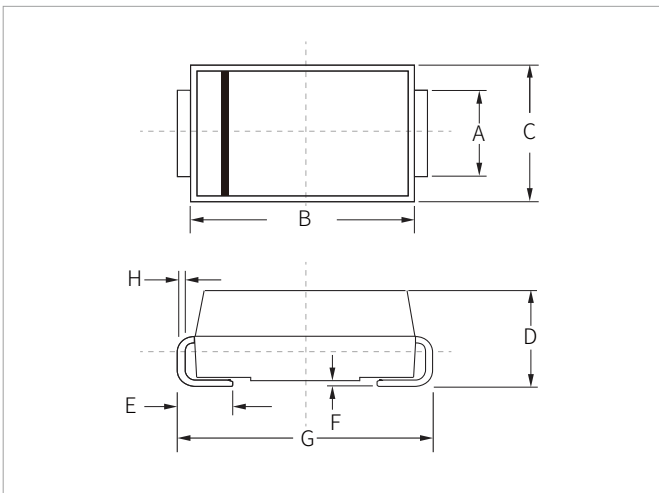
Reflow Condition		Lead-free assembly
Pre Heat	Temperature Max ( $T_{s(min)}$ )	150°C
	Temperature Max ( $T_{s(max)}$ )	200°C
	Time (min to max) ( $t_s$ )	60 – 180 secs
Average ramp up rate (Liquidus Temp ( $T_L$ ) to peak)		3°C/second max
$T_{s(max)}$ to $T_L$ - Ramp-up Rate		3°C/second max
Reflow	Temperature ( $T_L$ ) (Liquidus)	217°C
	Time (min to max) ( $t_l$ )	60 – 150 seconds
Peak Temperature ( $T_p$ )		260°C
Time within 5°C of actual peak Temperature ( $t_p$ )		20 – 40 seconds
Ramp-down Rate		6°C/second max
Time 25°C to peak Temperature ( $T_p$ )		8 minutes max.
Do not exceed		260°C



## DO-214AA(SMB) PACKAGE INFORMATION



Ref.	Millimeters		Inches	
	Min.	Max.	Min.	Max.
A	1.80	2.20	0.071	0.087
B	4.30	4.70	0.170	0.185
C	3.40	3.90	0.134	0.153
D	2.15	2.55	0.085	0.100
E	1.00	1.50	0.039	0.059
F	0.02	0.20	0.001	0.008
G	5.10	5.50	0.200	0.216
H	0.15	0.30	0.006	0.012

## RECOMMENDED PAD LAYOUT DIMENSIONS

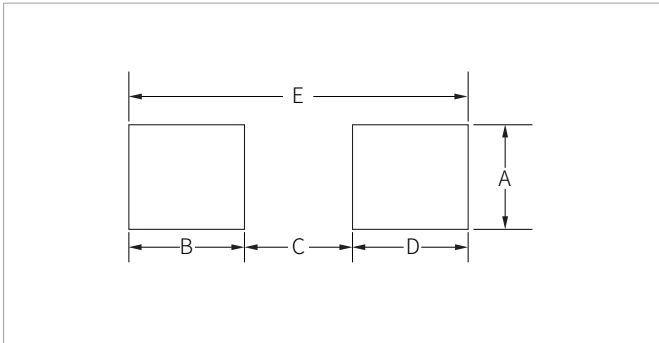

Ref.	Millimeters		Inches	
	Min.	Max.	Min.	Max.
A	2.20	-	0.087	-
B	1.45	-	0.057	-
C	-	2.55	-	0.010
D	1.45	-	0.057	-
E	5.60REF		0.220REF	

## ORDERING INFORMATION

Part Number	Component Package	QTY/Reel	Reel Size
SS1020B-SS10200B	DO-214AA(SMB)	3000PCS	13"

**Headquarters**

No.3387 Shendu Road  
Pujiang I&E Park  
Minhang Shanghai China  
201000

**Hotline**

400-021-5756

**Web**

<https://www.semiware.com>

**Sales Center**

Tel: 86-21-3463-7458  
Email: [sales18@semiware.com](mailto:sales18@semiware.com)

**Customer Service**

Tel: 86-21-5484-1001  
Email: [sales17@semiware.com](mailto:sales17@semiware.com)

**Technical Support**

Tel: 86-21-3463-7654  
Email: [fae01@semiware.com](mailto:fae01@semiware.com)

**Complaint & Suggestions**

Tel: 86-21-3463-7172  
Ext: 8868  
Email: [cs03@semiware.com](mailto:cs03@semiware.com)

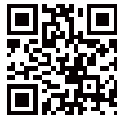
**By QR Code**

Website



Wechat

To find your local partner within Semiware' s global website: [www.semiware.com](http://www.semiware.com)

© 2022 Semiware Semiconductor Inc.

The content of this document has been carefully checked and understood. However, neither Semiware nor its subsidiaries assume any liability whatsoever for any errors or inaccuracies of this document and the consequences thereof. Published specifications are subject to change without notice. Product suitability for any area of application must ultimately be determined by the customer. In all cases, products must never be operated outside their published specifications. Semiware does not guarantee the availability of all published products. This disclaimer shall be governed by substantive Chinese law and resulting disputes shall be settled by the courts at the place of business of Semiware. Latest publications and a complete disclaimer can be downloaded from the Semiware website. All trademarks recognized.